

# LITHUANIA'S ROOTS IN THE POTTERY OF THE WESTERN SUBURBS OF MOSCOW OF THE 17TH AND 18TH CENTURIES

**OLGA N. GLAZUNOVA**

## Abstract

The article looks at possible ways and origins of cultural influence by the example of the pottery production of the New Jerusalem Monastery in the 17th and 18th centuries. It tells about the pottery of the New Jerusalem Monastery, and an attempt is made to trace signs of the influence of different craftsmen, and the situation in general for the development of pottery production and its special features.

Key words: New Jerusalem Monastery, pottery, tableware, thrown pottery, glaze, engobe, origin, Lithuania.

The Institute of Archaeology of the Russian Academy of Sciences has been conducting archaeological excavations and monitoring geological and other pits in the New Jerusalem Monastery since 2009. The works are pre-projective, so priority is given to the possibility of the practical use of material from archaeological research in the restoration of the monastery. However, the actual results, and in particular the archaeological collections obtained, have a much broader meaning, allowing us to view the facts from a new point of view, and to clarify and supplement various aspects of the history of the monastery (and others).

A comparison of the collection of pottery with the pottery of the western suburbs of Moscow, Belarus and Lithuania has allowed us to make some assumptions about the origin of its manufacturers. This work devoted to identifying various pottery traditions may provide additional material to reveal the origins of tile production in the New Jerusalem Monastery.

The pottery of the Moscow region has been studied and described by many researchers. This is primarily the work by Rabinovich (1949; 1971), Rozenfel'dt (1968), Koval (1999; 2001; 2004), Krenke (2004; 2011) and Chernov (1991; 2005). They offer different results for versions of types and development. In addition, there is a large number of articles on local pottery assemblages from different places near Moscow. Ceramics are also mentioned in more general archaeological studies. However, the Post-Medieval pottery of Istra is practically unknown. Material on this subject can only be found in unpublished reports of archaeological excavations, in particular the report by Gavrilin (1983) and some general ethnographic works on folk pottery (Kalmykova 1976; 1995).

The monastery was founded by Patriarch Nikon (1605–1681) in the middle of the 17th century, with the purpose of reproducing Jerusalem's holy sites in Russia. While in his homeland there were no deposits of the necessary dressed stone similar to what adorned the temples of the Holy Land, the patriarch planned to replace the stone decoration of the cathedrals with colourful glazed ceramic tiles. At that time, the tradition of decorating buildings with glazed tiles did not exist in Russia; even the technique of producing such tiles was unknown. To achieve his grandiose plan, Nikon tried to gather all the tile makers he could find, and organised the largest production of tiles in Russian history for architectural and domestic use.

The construction, started by Nikon and interrupted by the period of his disgrace, continued into the late 17th century.

The history of the monastery is not easy. The collapse in 1723 of the dome over the aedicule required considerable work to restore it. In the 1740s and 1760s, the large-scale restoration of the monastery buildings was led by the architect Ivan F. Michurin (1700–1763). Further restoration work carried out by Karl Blank (1728–1793) and Francesco Bartolomeo Rastrelli (1700–1771) largely destroyed the unique tiled interiors of the monastery, replacing tiles and murals with stucco work. The formation of the monastery buildings was completed during the 18th century, by the construction of the western and eastern brethren's buildings. In addition to these, a number of secular buildings and structures stood in the area of the monastery at different periods of time.

The beginning of the systematic study of the New Jerusalem Monastery is deservedly regarded as the work of Archimandrite Leonid Kavelin, the 'Historical De-

## IV

LIFESTYLE  
IN TOWNS,  
PALACES AND  
MONASTERIES

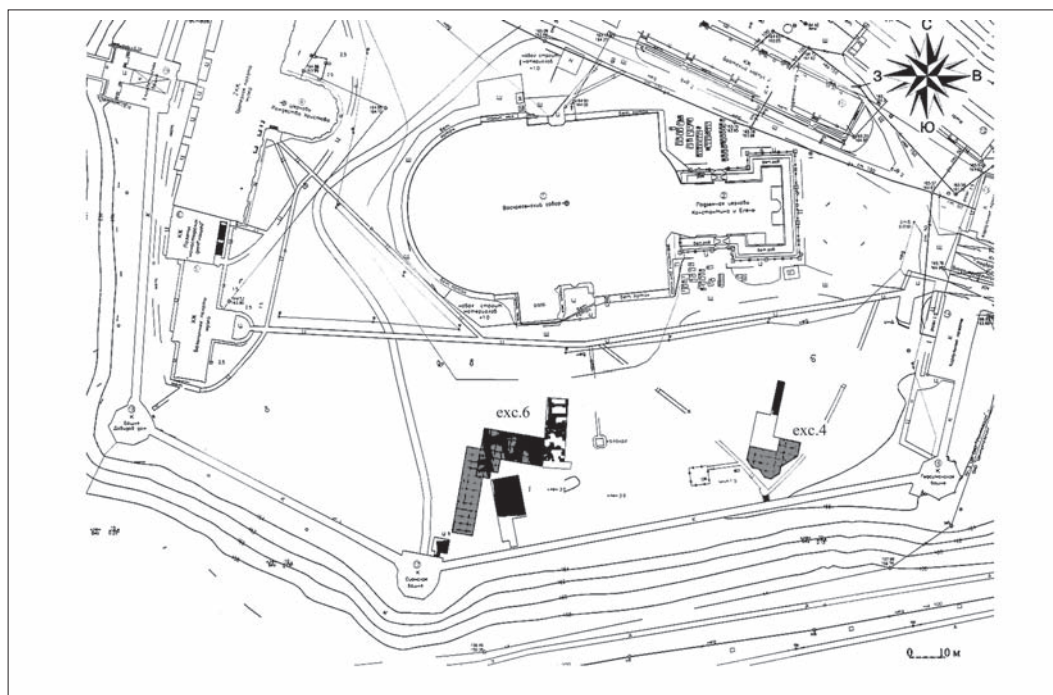

Fig. 1. Excavations in the New Jerusalem Monastery (map by Maksim Khodchenkov).

scription of the Stauropegial Resurrection Monastery, Called the New Jerusalem' (1867). It can now be used as a source of information. Literature on the phenomenon of the New Jerusalem Monastery is plentiful, and will not be presented in this article, because the actual theme of pottery (with the exception of architectural tiles) is not addressed in the works.

Before 2009 in fact, archaeological research on the monastery accompanied the restoration work, and it looked like small pits. We should mention the architectural and archaeological research by E.L. Hvorostovoy, and the disassembly of the interior of the palace of Tatiana Mikhailovna conducted by Ephraimov. Outside the monastery, K.N. Gavrilin conducted excavations near the Istra recreation centre in 1983. The finds from these excavations are stored in the collections of the Museum of the New Jerusalem Monastery, and were used for comparison with those obtained during excavations between 2009 and 2011.

During the excavations from 2009 to 2011, a total area of 3,754.66 square metres was uncovered, and more than 20 different buildings were discovered. A comprehensive collection of individual finds, tiles and pottery was accumulated. A total of 75,494 fragments of pottery, 30,948 fragments of architectural tiles, and 22,302 fragments of stove tiles were studied.

The pottery found illustrates the entire history of the monastery, from the mid-17th to the 20th century. There are even some pottery assemblages from earlier

times: one contains molded pottery from the early Iron Age, and at least another has pottery from the late 16th to the first half of the 17th century.

The special character of the pottery assemblage from the New Jerusalem Monastery is obvious at a glance. The pottery differs sharply from the pottery of the surrounding areas. Only 8% of the total amount of vessels is local pottery typical of the western suburbs of Moscow. As a rule, this ratio between local and imported/atypical pottery is the contrary.

The typical and special features can also be seen most clearly in three conditionally closed pottery assemblages: first, from the area of the fourth excavation, where the residence and other buildings from Nikon's time were founded; second, connected with an abandoned bell-casting complex (the sixth excavation plot, pit 4) (Fig. 1); the third one originates from the filling of some pits of the sixth excavation plot related to the civilian building the 'Marble Palace'.

The stratigraphy of the fourth excavation plot contains one layer dated to the time of Patriarch Nikon. Above this layer, there is only a small layer of ballast; below is the natural subsoil. Numismatic material is represented by numerous (54 pieces) copper and silver kopecks (made during the reign of Mikhail Fedorovich [1613–1645] and Aleksei Mikhailovich Romanov [1645–1676]), a Swedish shilling from the same time (1632–1654), and a 'golden ugric'. We found tiles from at least four ovens. They are the earliest in this area,

and represent several different traditions: the Moscow tile school, craftsmen from Kopys (Belarus), the Lithuanian tradition of carpeting tiles, and a stove made in the West European manner.

In the filling of the fourth pit of the sixth excavation plot, above the remains of the bell-casting complex, lay a stratum consisting of fragments of architectural tiles from the original decor of the Resurrection Cathedral, and fragments of three-colour roof tiles. Apparently, these are real evidence of the collapse of the roof of the dome.

Above this layer, another layer of dark-grey sandy loam with construction and household refuse was located. Within this layer, a collection of pottery was found. In addition to the dishes, also fragments of 'Dutch' ornamented pipes with a long cigarette holder and tulip cups (12 pieces), including the stigma of Insurance under the image of a crown (a brand owned by the craftsman Cornelius Kwastu, dated 1730), and a few coins from the first half of the 18th century were found. The layer from the Michurinsky period of the reconstruction of the cathedral is documented above. So the filling of the pit formed after the collapse of the roof of the dome of the cathedral in 1723, and before the erection of a new one in 1759. We can therefore narrow the date of the layer to the 1730s or early 1740s.

In the filling of the pits of the sixth excavation relating to the 'Marble Palace', in addition to the pottery, fragments of smooth painted oven tiles in the 'French royal style' were found, dating from the third quarter of the 18th century, and a few coins from the same time.

The pottery from the layer of Nikon's time from the fourth excavation plot is assumed not to belong directly to the patriarch. He organised the manufacture of pottery not only for the needs of the monastery itself, but also for sale and as gifts. The large number of decorated tiles, ceramics and floor tiles found in the excavations allow us to assume the existence a warehouse on this site where manufactured products were kept. The complex contains unused architectural tiles and semi-finished ones without glaze. Moreover, there are tiles that are unknown at present, and historically fairly certainly the decoration of the cathedral. There is a large number of tiles of the same type: for example, 34 identical keystones of arches. There are tiles with cut marks used to complete some composition, and broken at the moment of firing with trickled glaze in the cracks. The same can be said about the pottery. The assemblage contains a large number of identical vessels, or vessels with a very similar design: a whole stack of bowls, cups and miniature lamps. It consists of ready-made products, covered with glaze, and semi-finished ones without glaze.

The most impressive alien ceramic vessel is the three-legged pan-roaster, from the fourth excavation plot, in the layer from Nikon's time. It is a round (21 centimetres in diameter) and rounded-sided vessel with low sides, a slightly rounded (not flat) base, and the rim is skewed inwards. The legs are round in section, and tapering to the bottom. The vessel also has a round hollow handle-sleeve. The pan was made from red clay, has a sand-tempered paste and is covered inside with green (*muravlenaya*) glaze. Such vessels are extremely rare in the Moscow region; it is mostly imported dishware, differing sharply from the local Moscow pottery in the paste and the quality of the glaze. However, it is an absolutely normal type for any European country. Fig. 2 shows a similar three-legged pan from Klaipėda (17th century) (Fig. 2).

The rest of the pottery assemblage consists of mainly glazed tableware (this is also absolutely not the case for the Moscow region), pots with conical sides and jars, including one with carelessly scratched outline floral decoration under glaze. Also, a set of fairly large (eight to 12 centimetres in diameter) mugs with straight sides, and straight (zoomorphic) handles (similar to modern beer mugs) were found. Some mugs are green glazed, some coloured glazed, and some without any glaze. Typical of the Moscow tradition are rounded-sided mugs-jars or tumblers with conical sides (Fig. 3).

There is some other domestic glazed pottery: a ceramic miniature lamp and a very interesting sealed flask of complex shape, with double sides and circular holes in the upper surface of the vessel. This may have been used as censer or a candle holder (Fig. 4).

In this complex we can see attempts to reproduce foreign objects with locally available materials. The emphasis is on physical resemblance. The paste (local red clay with a lot of sand) is similar to the local pots of that time. The glaze, on visual inspection, is absolutely identical to the glaze of tiles.

The pottery assemblage from the abandoned bell-casting complex contains 13 items. First of all there are six medium-sized (10.5 to 15.5 centimetres in height), thin-sided (no more than 0.4 centimetres), hard fired, smooth egg-shaped pots on a small underpan, with a characteristic slope of neck (a widening cone-shaped neck) and round handle. The diameter of the necks differs from 12 centimetres to 16 centimetres, the diameter of the bases from eight centimetres to 11 centimetres (the ratio of the height to the width of the neck is respectively from 0.7 to 1.3).

The paste is untempered. Three pots are covered with green glaze inside and engobe outside; one pot has a turquoise glaze inside and engobe outside. The rest are

## IV

LIFESTYLE  
IN TOWNS,  
PALACES AND  
MONASTERIES

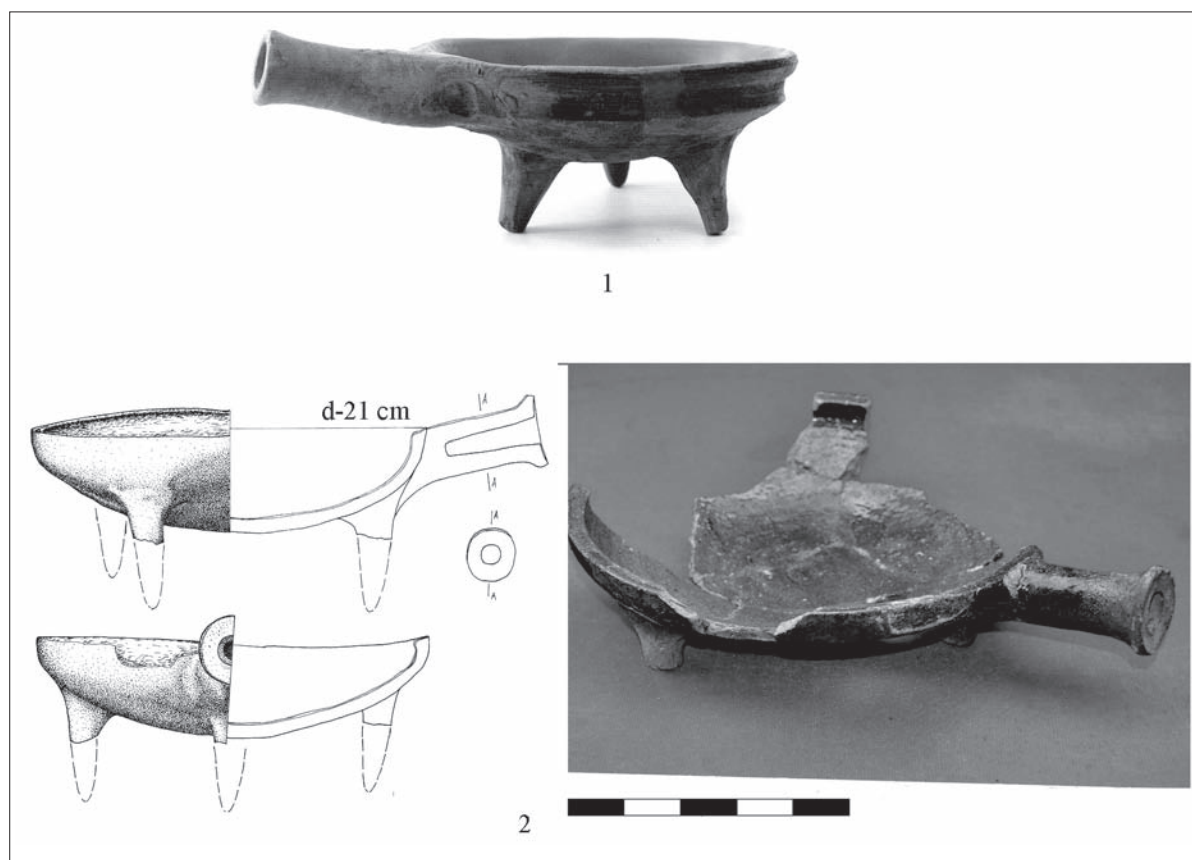

Fig. 2. Three-legged pans: 1 from Klaipėda (after *Klaipėdos pilies*, 2010, No. 65); 2 from the New Jerusalem Monastery, excavation plot 4 (drawing by Aleksei Sergeev, photograph by O.N. Glazunova).

covered with engobe only on the outside. Four pots have handles, two do not. A zoomorphic water tank, resembling them in its shape and paste, was also found. It had two handles and two gracefully curved spouts, decorated with horns. This vessel is covered with green glaze inside and with engobe outside, but it is also decorated with an arbitrary pattern of jets of the same green glaze over the engobe.

This material in the New Jerusalem Monastery is not typical crockery for Moscow or the Moscow suburbs. At the same time, if we turn to the pottery of Lithuania, we will find that such pots, albeit slightly taller (16.6 to 19 centimetres), existed in Lithuania during the 17th and 18th centuries, and constituted the basic mass of crockery (for this, see *Klaipėdos pilies* 2010, pp.19-25, Nos. 21-24, 25, 49). This shape has a wide distribution, as far back as the 14th century on Hansa territory, and since the mid-17th century the insides of these pots were glazed and the outside was covered with engobe (Fig. 5).

Rough cookware includes large pots of two types presented in the pottery assemblage of the New Jerusalem Monastery with two integer forms, fundamentally different in paste. The paste of the first pot contains a

large amount of grit and coarse sand, and not just on the edge, but also on the whole surface of the vessel, both internal and external. This can be noted as a characteristic feature of the cooking ware of all the western suburbs of Moscow (Istria, Mozhaisk, Zvenigorod, and so on). The paste of the second pot is made of red clay with inclusions of organic matter and fine sand; the surface is smooth.

At the same time, both pots have common features, such as the large size (18 centimetres/26 centimetres in height), the wide neck (18 centimetres/24 centimetres), an incomplete (three layers) firing, and heavy sides (0.7 to one centimetre thickness), as well as an outward folded rim and a wide base (Fig. 6).

A large pot with a drain (for curd?) can also be attributed to the cookware, its paste being untempered and similar to the paste of dining pots.

So we can find at least three different pottery traditions in this pottery assemblage.

The pottery assemblage from the Marble Palace (the third quarter of the 18th century) still kept the tendency for the presence of forms of vessels untypical of the Moscow region, and showed a new feature, the use of



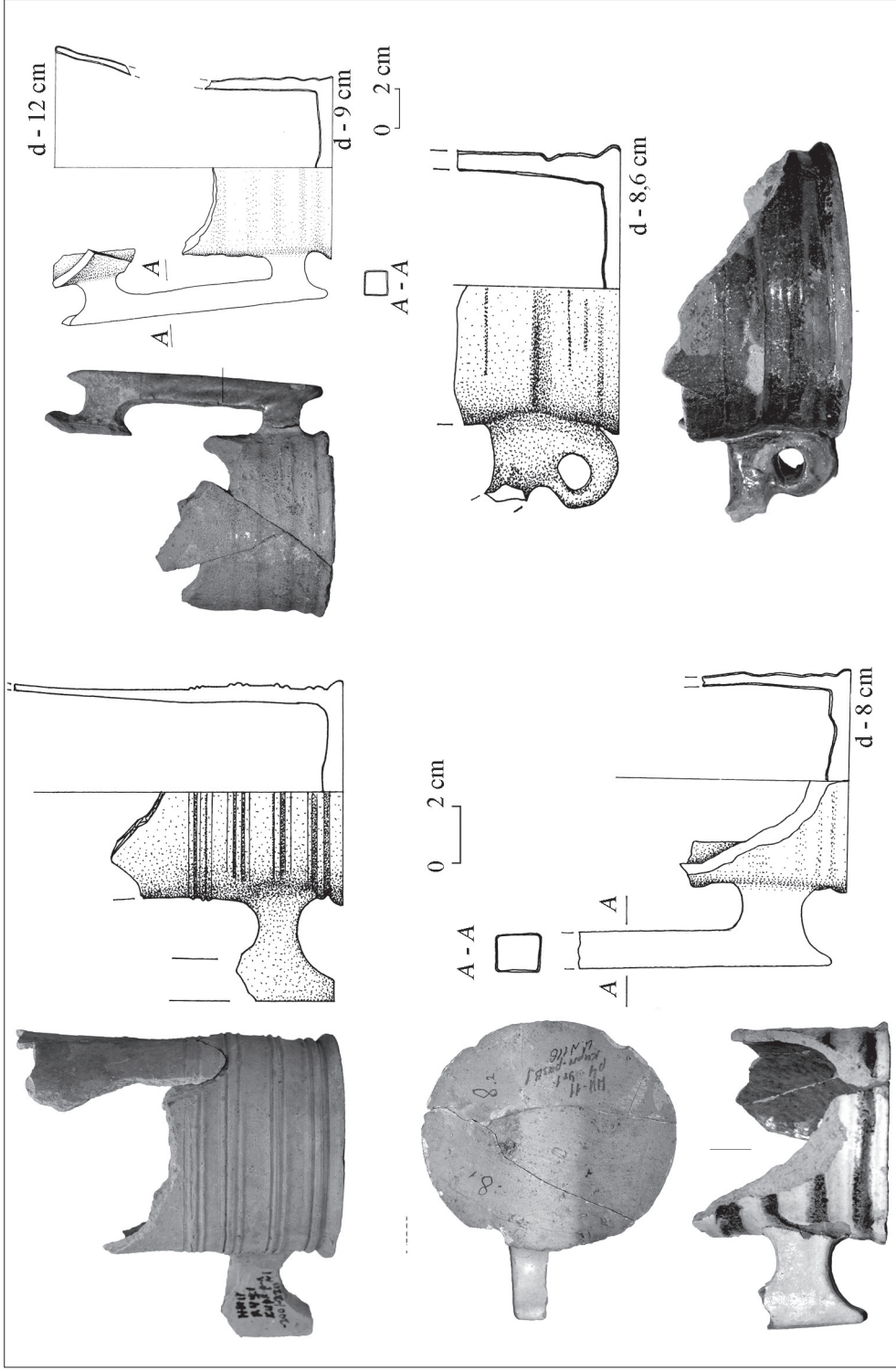

Fig. 3. Mugs from the New Jerusalem Monastery, excavation plot 4 (drawings by Maksim Khodchenkov).

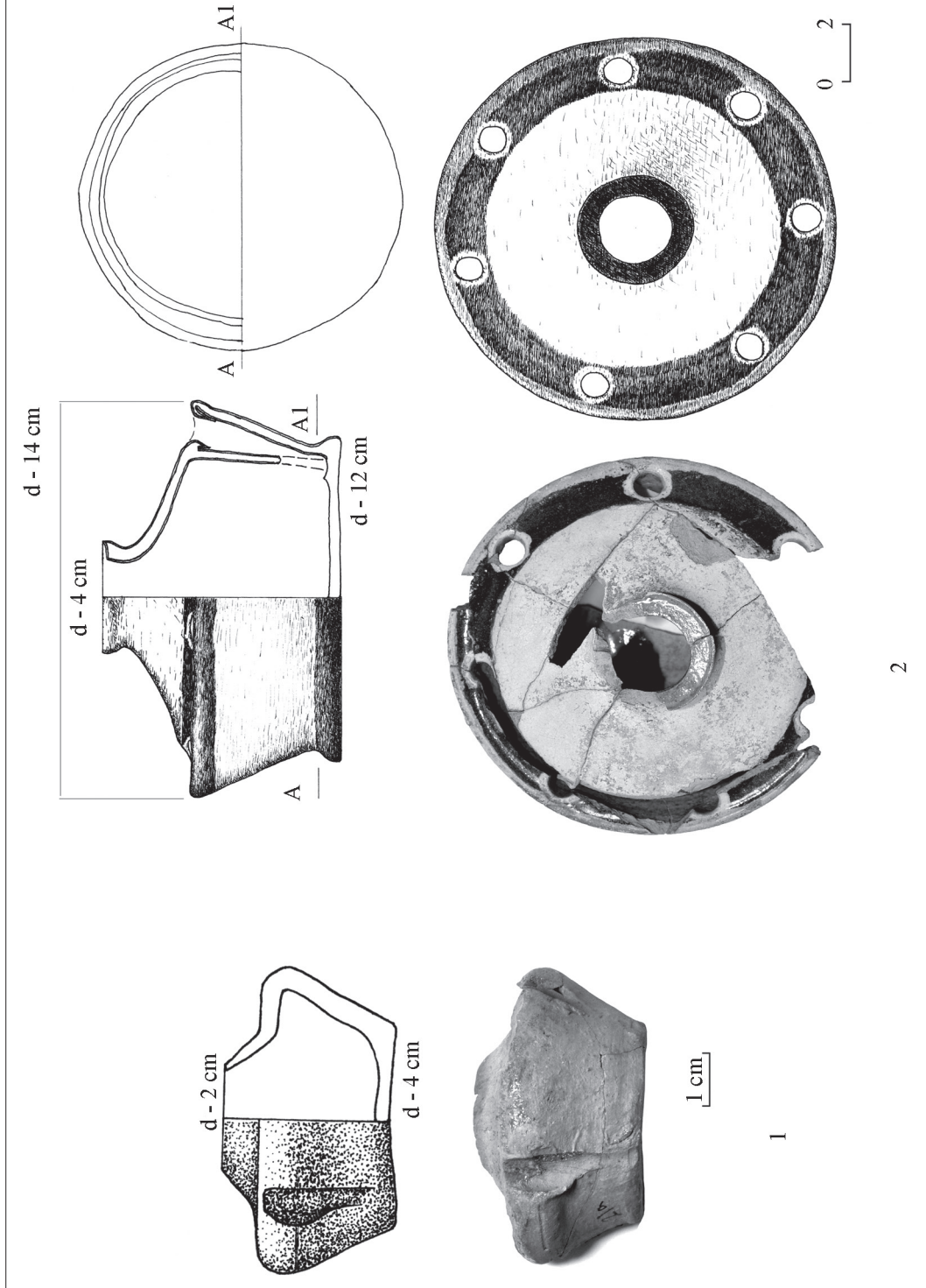

Fig. 4. A lamp (1) and censer (2) from the residence of Patriarch Nikon (drawings by Aleksei Sergeev).

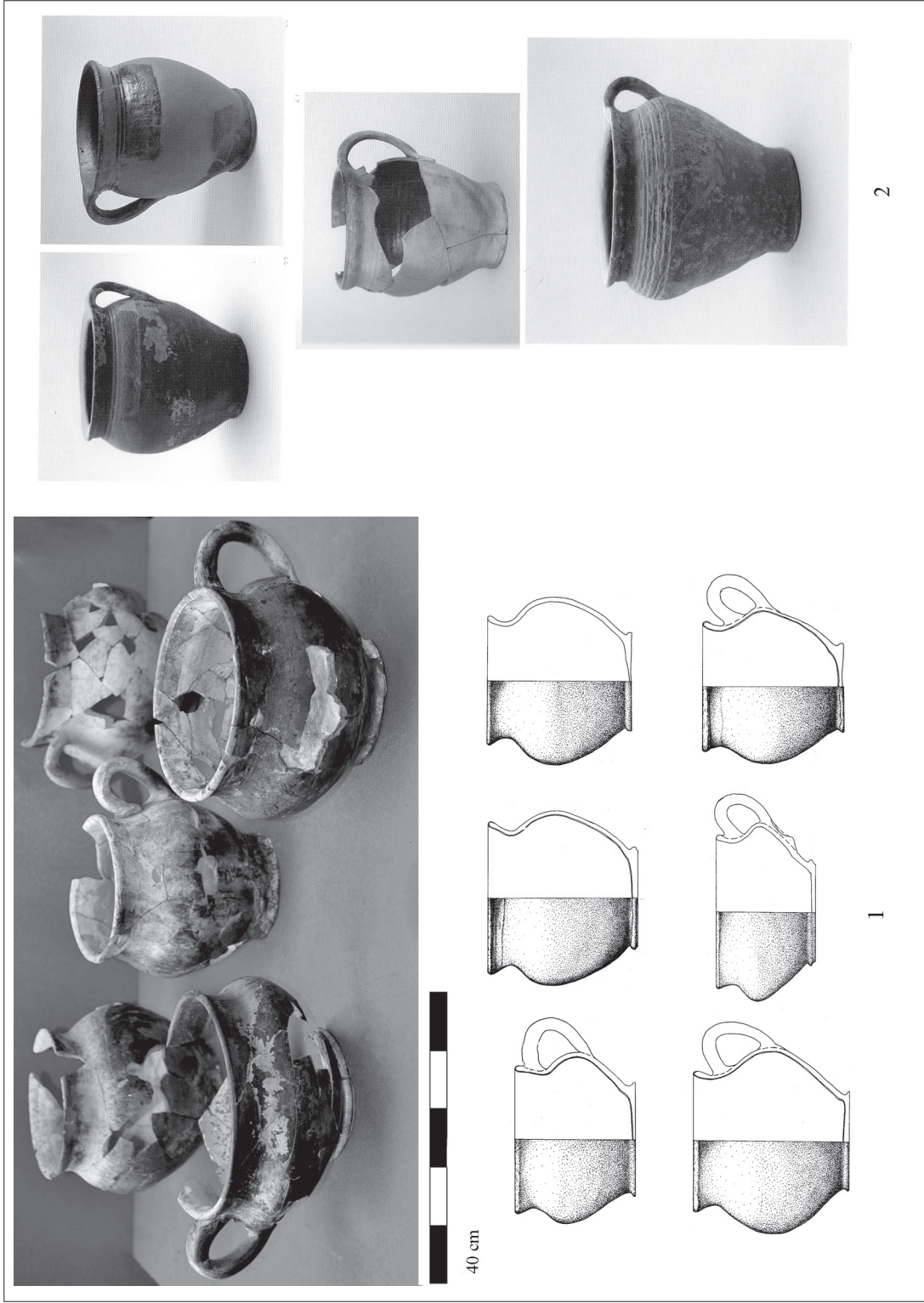

Fig. 5. Tableware: 1 from the New Jerusalem Monastery, excavation plot 6 (drawings by Aleksei Sergeev, photographs by O.N. Glazunova); 2 from Klaipėda (after *Klaipėdos pilies*, 2010, Nos. 22-25).



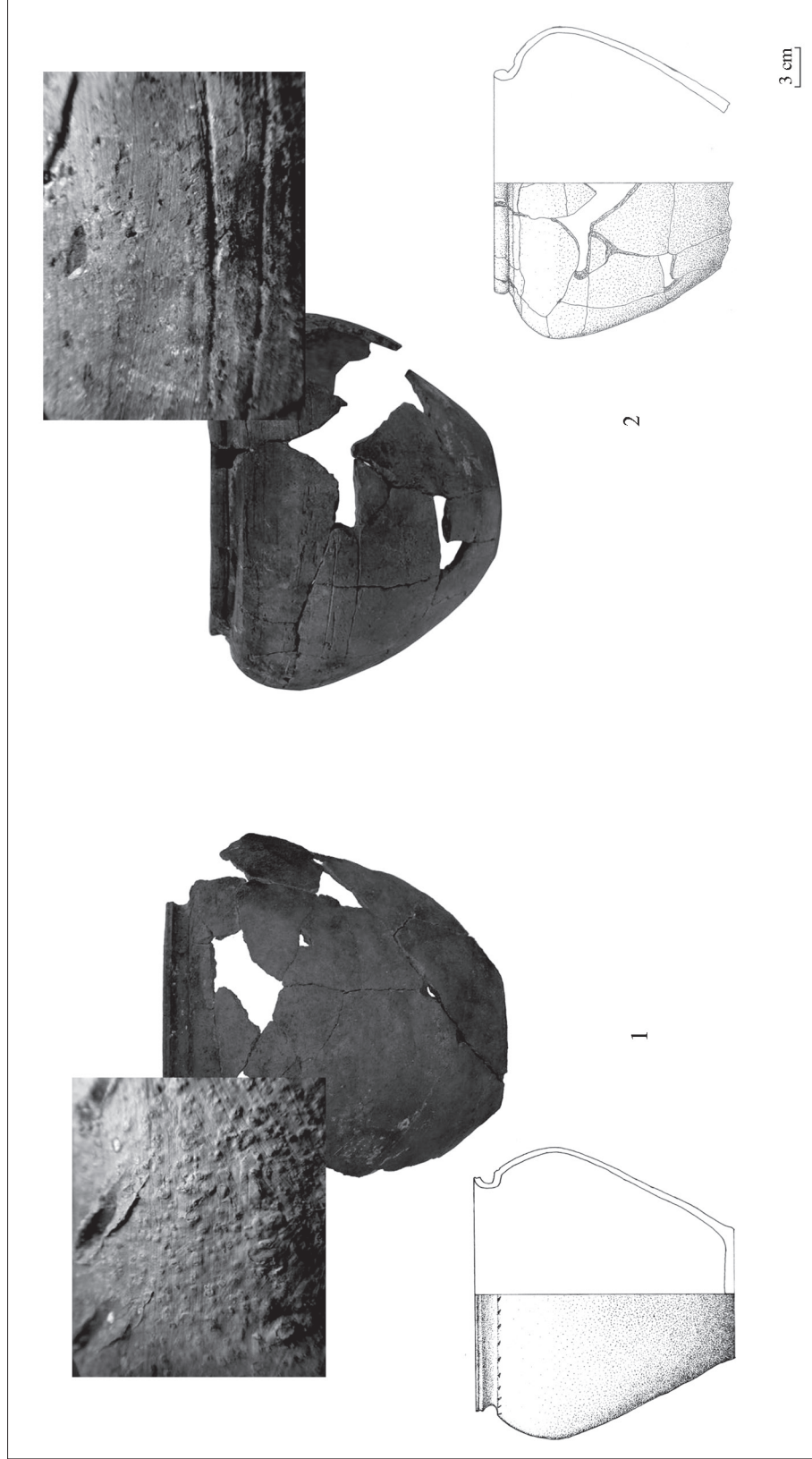

Fig. 6. Large vessels from the New Jerusalem Monastery, excavation plot 6: 1 with grit in the paste; 2 with organic material (?) in the paste (drawings by Aleksei Sergeev, photographs by O.N. Glazunova).



a large variety of colourful glazes in different combinations.

So it is very similar to the Lithuanian lids of vessels, which are different to the usual flat Moscow lids (Fig. 7).

The next category of dishes is ceramic plates. Clay table plates appeared in Lithuania in the 16th century, and were widely disseminated up to the 17th century. This type is quite untypical of Moscow pottery. Tableware was usually represented by wooden bowls, small clay pots, or just sometimes clay bowls. In the New Jerusalem Monastery, dining clay plates make up a large percentage of the total amount of tableware. They are characterised by multi-coloured underglaze painting

over the white engobe. We can find the same in Lithuanian pottery (Fig. 8).

On the edges of several plates of the New Jerusalem Monastery material, a pattern could be detected which is familiar to us from painted tiles, the '*flegnerovskie daisies*' (Fig. 9), which confirms the assumption that glazed pottery was made in the monastery in the same workshops and by the same craftsmen who produced the tiles. Another indirect proof of this is the unusually diverse mix of different glaze and engobe on the pottery. We had to create special separate tables of combinations of colours of glaze and engobe to calculate and determine the Istra pottery.

Here is an example of such a table:

outer surface (dishes - inside)	inner surface (plates - external)	set of	number
marble painting under a colourless glaze	no	jar plate cover	7
marble painting under a colourless glaze	brown glaze	cover pot	10
marble painting under a colourless glaze	turquoise glaze		1
marble painting under a colourless glaze	green glaze	jar	2
painting under a colourless glaze	green glaze	jar	1
painting under a colourless glaze	yellow glaze	plate	3
painting under a colourless glaze	turquoise glaze		1
painting under a colourless glaze	no	glass	1
painting under a colourless glaze	yellow stripes		1
painting under a colourless glaze	brown glaze		1
white glaze	no	plate	1
white glaze	green glaze		1
engobe	no	mug pot jar	7
engobe	green glaze	mug jar	12
painting over engobe	brown glaze		1
painting over engobe	green glaze		1
green glaze	brown glaze		2
turquoise glaze	yellow glaze		7
turquoise glaze	green glaze	plate	2
turquoise glaze	turquoise glaze	mug	5
no	turquoise glaze		3
no	brown glaze	jar	7
no	dark blue glaze	pot	1
brown glaze	no	jar	1
brown glaze	turquoise glaze	mug	2

IV

LIFESTYLE  
IN TOWNS,  
PALACES AND  
MONASTERIES

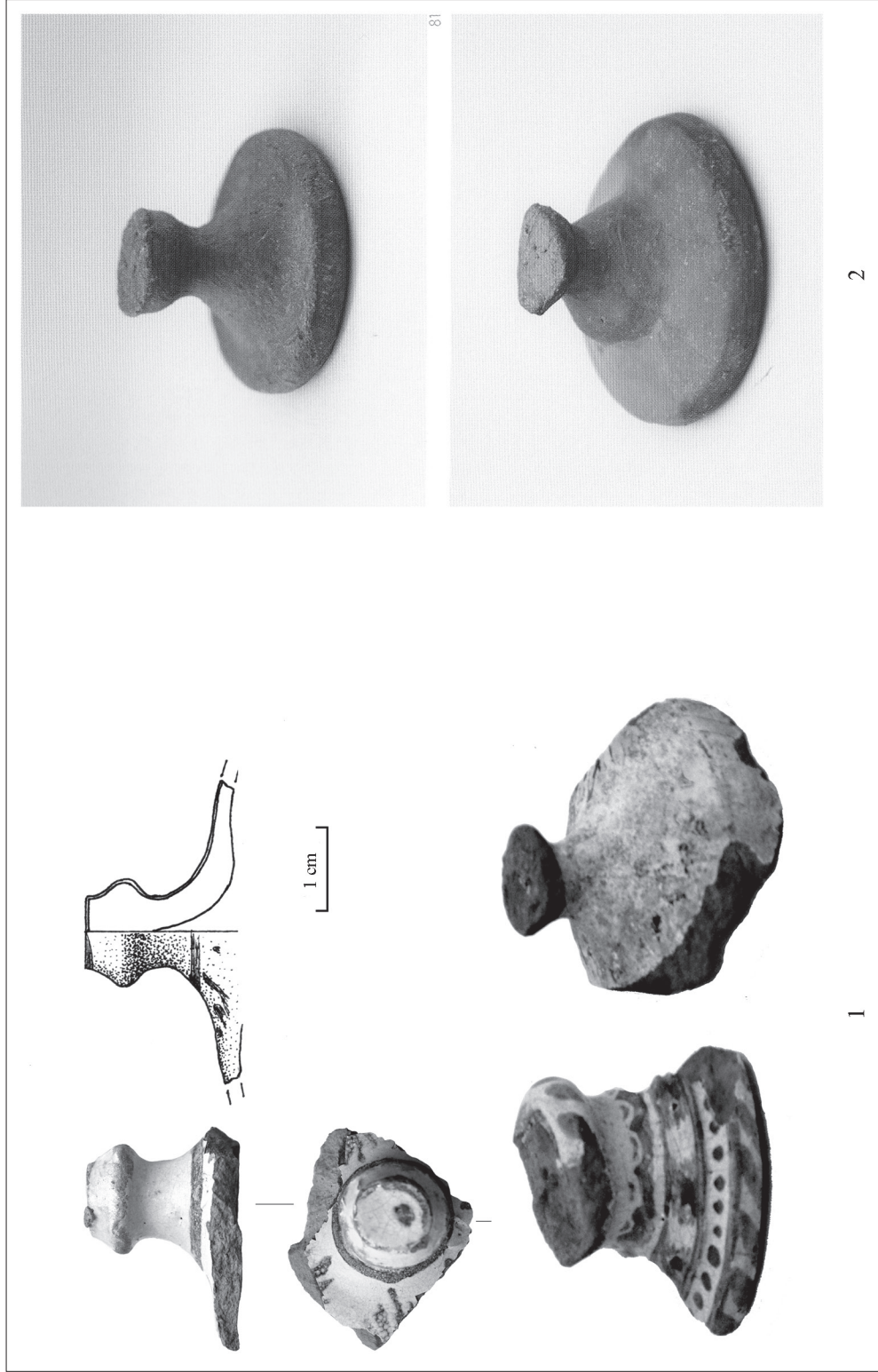

Fig. 7. Lids: 1 from the New Jerusalem Monastery, excavation plot 6 (drawings by Maksim Khodchenkov, photographs by O.N. Glazunova); 2 from Klaipėda (after *Klaipėdos pilies*, 2010, Nos. 80, 81).

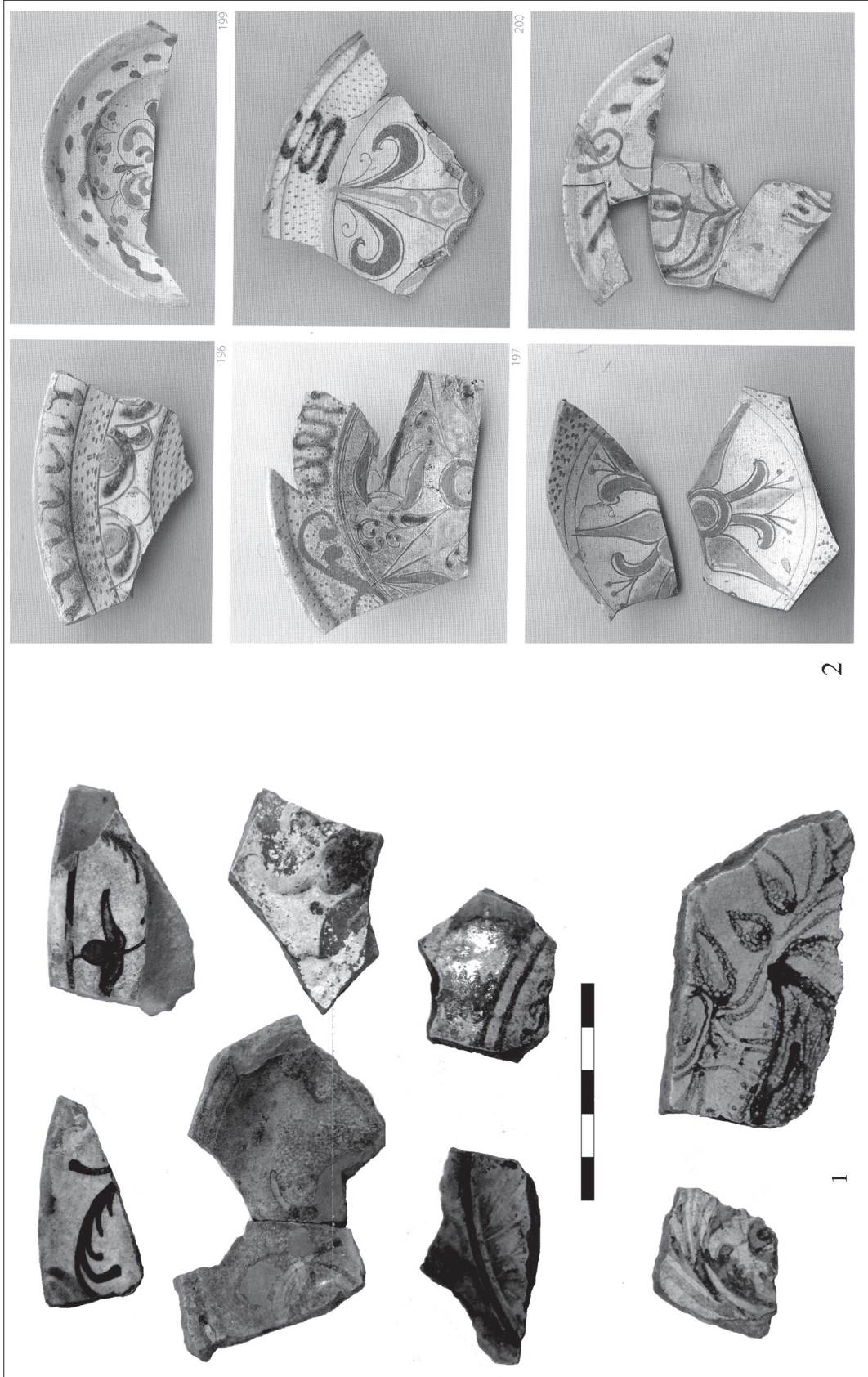

Fig. 8. Fragments of plates: 1 from the New Jerusalem Monastery, excavation plot 6; 2 from Klaipėda (after *Klaipėdos pilies*, 2010, Nos. 196-201).

IV  
LIFESTYLE  
IN TOWNS,  
PALACES AND  
MONASTERIES



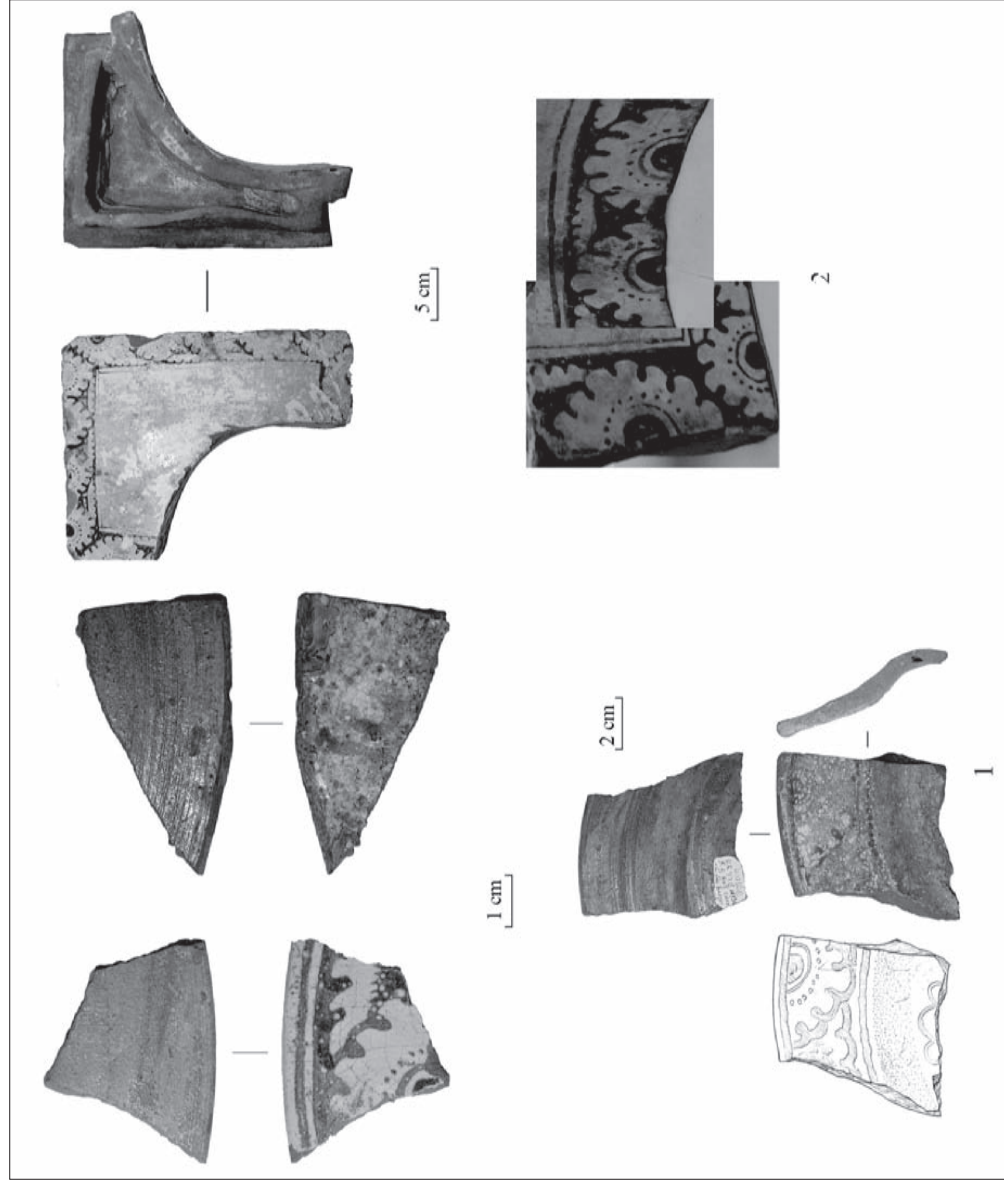

Fig. 9. A decorative border from the New Jerusalem Monastery: 1 on plates; 2 on tiles (drawings by Aleksei Sergeev, photographs by O.N. Glazunova).

Practical economy does not usually allow such diversity to exist in a real production process. It is possible only if the craftsman has access to a great variety of glazes used in large quantities for other purposes, in our case, for the manufacture of tiles. The pottery production used the remains of the tile production.

To sum up, it is possible to conclude that:

1. A variety of ceramic glazed products untypical of Moscow was produced in the workshops of the New Jerusalem Monastery in the middle of the 17th century. Among them there are three-legged frying pans, mugs and miniature lamps. Some of the items are similar to Hansa pottery types.

2. Glazed dining pots covered with engobe from the second third of the 18th century (with handles and without) have direct analogies with the everyday pottery of Lithuania.

3. Clay plates with underglaze painting appear in the dining pottery of the New Jerusalem Monastery in the third quarter of the 18th century. This type of pottery is not conventional for Moscow, but widespread in Lithuania.

4. Lids of vessels from the 18th century are similar to Lithuanian ones, and differ sharply from the flat Moscow specimens.

5. Kitchen pottery in Istra from the second third of the 18th century was made from red clay and is represented by three main types. The first type is relevant to the western suburbs of Moscow as a whole. The origin of the second is still unclear. The third may be associated with Lithuanian potters.

6. The unusually large amount of glazed pottery, the identity of the glaze and sometimes the pictures on the tiles and pottery, and the huge variety of different combinations of glazes, make it possible to say that tableware was manufactured in the same workshops as tiles.

## References

### Manuscripts

GAVRILIN, K.N., 1983. Otchet o spasatel'nikh raskopkakh keramicheskoi masterskoi pervoi chetverti XVIII veka v g. Istra (unpublished excavation report). *In: Archive Institute of Archaeology of Russian Academy of Sciences. Moskva.*

## Literature

- CHERNOV, S.Z., 1991. K khronologii moskovskoi keramiki konca XV-XVI vv. *In: Moskovskaiia keramika: Novye danniiye po khronologii.* Moskva, 50-55.
- CHERNOV, S.Z., 2005. Domen moskovskikh kniazei v gorodskikh stanakh. 1271–1505 rr. *In: Kultura srednevekovoi Moskvi: Istoricheskie landshafty, 2.* Moskva.
- KALMYKOVA, L.E., 1976. *Russkoe goncharnoe isskusstvo XIX-nachala XX veka. Katalog vystavki iz sobraniia Zagorskogo muzeia.* Moskva.
- KALMYKOVA, L.E., 1995. Katalog "Narodnoye goncharstvo Moskovskoi oblasti XIX - nachala XX vv." Moskva: Soreki.
- KLAIPĖDOS PILIES, 2010. *Klaipėdos pilies ir senamiesčio buitinė keramika XIV a. vid. – XIX a. Iš Mažosios Lietuvos istorijos muziejaus rinkinių.* Compilers R. Songailaitė, L. Rutkaitienė. Klaipėda: Mažosios Lietuvos istorijos muziejus.
- KOVAL, V.IU., 1999. Statisticheskaiia obrabotka arheologicheskoi keramiki srednevekovoi Moskvi. *In: Tver; tverskaia zemlia i sopredel'niye territorii v epokhu srednevekov'ia, 3.* Tver, 123-130.
- KOVAL, V.IU., 2001. Beloglinianaya keramika v srednevekovoi Moskve. *Rossiskaiia archeologiiia, 1,* 98-109.
- KOVAL, V.IU., 2004. Issledovanie keramicheskogo materiala. *In: Srednevekovoe poselenie Nastas'ino. Trudi Podmoskovnoi ekspeditsii IA RAN, 2.* Moskva, 21-39.
- KRENKE, N.A. (ed), 2004. Kul'tura srednevekovoi Moskvi. Istoricheskie landshafty, 1. Rasselenie osvoenie zemel' i prirodnaia sreda v okruge Moskvu XII–XIII vv. Moskva.
- KRENKE, N.A., 2011. Drevnerusskaiia keramika moskovskogo regiona: klassifikaciia, hronologiiia. *In: Arkheologiiia i istoriia Pskova i Pskovskoi zemli. Materialy zasedaniia seminara imeni akademika V.V.Sedova, 56.* Moskva-Pskov.
- NAVIKIENĖ, V., ed. 2000. *Keramika Utenos krašte.* Kaunas: Arx Baltica.
- RABINOVICH, M.G., 1949. *Moskovskaiia keramika.* *In: MIA, 12.* Moskva–Leningrad.
- RABINOVICH, M.G., 1971. Kul'turnyi sloi central'nykh raionov Moskvu. *In: Drevnosti Moskovskogo Kremliia.* Moskva.
- ROSENFEL'DT, R.L., 1968. *Moskovskoie keramicheskoe proizvodstvo XV– XVII vv.* *In: Svod arkheologicheskikh istochnikov, vypusk E-1-39.* Moskva.

Received: 17 November 2011; Revised: 9 December 2011; Accepted: 20 December 2011.

Olga N. Glazunova  
Institute of Archaeology  
Dm. Ul'anova St 19,  
17036 Moscow, Russia  
E-mail: olga-glazunova2007@yandex.ru

## IV

LIFESTYLE  
IN TOWNS,  
PALACES AND  
MONASTERIES

## LIETUVIŠKOS ŠAKNYS XVII–XVIII A. VAKARINIŲ MASKVOS APYLINKIŲ MIESTŲ KERAMIKOJE

**OLGA N. GLAZUNOVA**

### Santrauka

Straipsnis yra skirtas XVII–XVIII a. keramikos, rastos Naujosios Jeruzalės vienuolyne, kuris yra Istros (40 km į vakarus nuo Maskvos) mieste, galimoms kultūrinės įtakos kilmės paieškoms (1 pav.). Straipsnyje taip pat aptariama įvairių meistrų įtaka ir bendra keramikos, rastos Naujosios Jeruzalės vienuolyne, raida bei jos specifiniai bruožai.

XVII–XVIII a. virtuviniai indai, rasti Istroje, yra gaminti iš raudonojo molio ir priklauso dviem pagrindiniams tipams. Pirmojo tipo keramika yra būdinga vakariniams Maskvos apylinkių miestams. Antrojo tipo virtuvinių indų kilmė iki šiol neaiški. Tačiau galima manyti, kad šis tipas yra susijęs su regionu, kuriame buvo įprasta keramikinius indus gaminti iš baltojo molio.

Stalo indai, kurie yra padengti glazūra ir angobu, tokie kaip indų dangčiai, keptuvės, dubenys, turi tiesioginių analogijų Klaipėdos (Lietuva) miesto keramikoje ir apskritai Hanzos miestų sąjungos keramikoje. Neįprastai didelis kiekis glazūra dengtos keramikos, glazūros, kuri dengia indus ir koklius, identiškas, kaip ir tapatus dekoras ir didelė jo įvairovė, įgalina teigti, kad ši keramika buvo gaminta tose pačiose dirbtuvėse (2–9 pav.).

Vertė Audronė Bliujienė