

# RITUAL KNOWLEDGE: THE PRODUCTION, DISTRIBUTION AND DEPOSITION OF LATE BRONZE AGE HANGING VESSELS

IMMO HESKE

## Abstract

The article presents aspects of the cultural function of Nordic Bronze Age hanging vessels, on the basis of their distribution and production in the Baltic Sea region. Depositions with hanging vessels and related objects show for some regions a similar understanding of the right use and ritual knowledge.

Key words: Late Bronze Age, Baltic Sea, hanging vessels, metalwork, casting moulds, hoards.

## Introduction

Late Bronze Age hanging vessels are some of the most popular and important finds from the Nordic Bronze Age. The distribution of hanging vessels and the circumstances of how they get into the ground are the results of various changes during the Bronze Age. In the Middle Bronze Age, they were often used as grave goods; but in Periods IV and V most were deposited in hoards along with other bronze artefacts. Together with lurs, they are high-quality results of indigenous metalwork, which indicates a very high level of knowledge. Hanging vessels are produced by casting them in clay moulds. Parts of the decoration are incorporated into the casting mould, but most is added in a very fine style after the clay mould has been removed. The remains of local production are difficult to identify from fragments of burnt clay in settlements. The production, distribution and deposition in the Nordic Bronze Age and peripheral regions are discussed. Indications of a different understanding of the 'right' form of use and deposition are shown. To comply with the title of the paper, a wider look at the area from the Netherlands in the west to Latvia in the east is taken.

With the beginning of archaeological interest and the first identification of this group, especially the hoard of Neulingen, Kr. Stendal, discovered in 1719 (Sprockhoff, Höckmann p.357f) (Fig. 1), which is lost today (Sprockhoff, Höckmann 1979, p.102), hanging vessels became one of the most fascinating archaeological objects. The profile of vessels with a curved bottom and rich decoration raises many questions, but most of them are still unanswered today, especially the 'right use' between jewellery and ritual function (Sprockhoff, Höckmann 1979, p.16).

How to interpret grave goods and depositions from Period II and Period III (after Montelius) brings us back to the old question whether they are personal goods called *Totenschätze*, a personal assemblage for the afterlife, a deposition by a lost trader, or a gift for the gods. An analysis of many hoards from these periods reveals restricted and regional combinations. Artefacts can vary between regions and periods (Hundt 1944-1950, p.207; Willroth 1985, p.395, Fig. 13). In order to find the right interpretation for one period, we have to ask if this behaviour is 'modern' in the next period of the Nordic Bronze Age.

Another issue, discussed by S. Müller (1878, p.30) and E. Sprockhoff (1966, p.110), takes a look at the *Werkstätten-* and *Handwerkerkreise*, focusing on the art of casting and decoration. Rich decorations with different themes and motifs sometimes show regional traditions (Höckmann 1974, p.90; 1981, p.89) or the signature of a specialised craftsman. The connection between these widespread find spots offers a glance at connections between regions or settlement groups.

## Hanging vessels from Period III and Period IV

At the first approach, it is necessary to remember the hanging vessels of Period III with their find situations in graves and depositions, and then trace the development in Period IV and Period V. We should follow the thoughts of W.A. v. Brunn, who took the first steps in the early 1980s (v. Brunn 1980, p.99).

In Period III, 14 finds of hanging vessels are known in southern Sweden and the Danish isles. Graves and depositions counterbalance each other. Bronze and/or golden spiral-rings for hair or arms and sometimes a knob and/or a knife are characteristic of them. The dep-

## I

EARLY METAL AGE SOCIETIES: FROM A THEORETICAL ASSESSMENT TO THEIR ECONOMY, INTERREGIONAL CONTACTS AND RITUALS

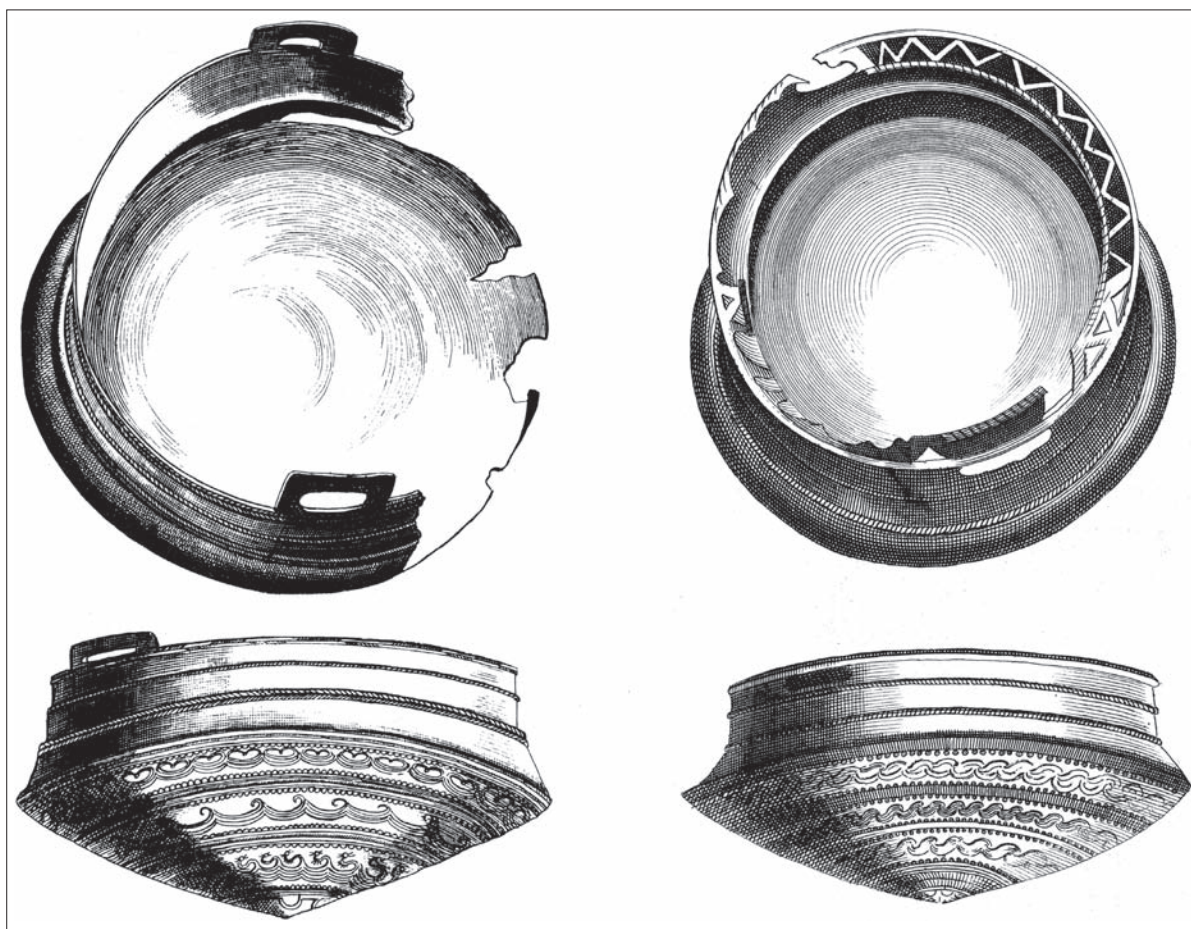

Fig. 1. Hanging vessels from Neulingen, Kr. Stendal, found in 1719 and lost today (after Sprockhoff, Höckmann 1979, Plates 280-281).

ositions were laid down in wet surroundings, for example in Brunsmose, Ksp. Flemløse (DK; Aner, Kersten 1977, p.107, Plates 67, 1745). One hanging vessel with a star pattern, four small gold spiral-rings, one pair of bronze spiral arm-rings, a belt knob and a tang knife were found (Fig. 2). The contents of the depositions are very similar to those of the graves, both include spiral arm-rings, belt knob and tang knife. Gold spiral-rings are often found in depositions, and are part of every hoard with hanging vessels. However, only two graves with hanging vessels contain gold spiral-rings. Other objects, like various neck-rings and fibulae, are only found in graves (Willroth 1985, Fig. 19). The depositions seem to be votive offerings, and not equipment for the afterlife (Willroth 1985, p.395).

Depositions of hanging vessels are a very important group of finds in Period IV of the Nordic Bronze Age. The impact of finds increases in the core regions of the Nordic Bronze Age. This is shown clearly in the data for Denmark. At first only located on the Danish isles with 14 examples in Period III, there are 54 hoards with more than 65 vessels in Period IV (Fig. 3) (Hundt 1944-1950, p.198, maps 1-2; Willroth 1985, p.381; Sprockhoff, Höckmann 1979). In the southern

area of the Baltic Sea, 26 depositions are known from recently. Five hanging vessels were found west of the River Elbe, and 21 in Schleswig-Holstein and the Pomeranian area.

Limited and regular contents are characteristics of depositions. A good example from the Lower Saxony area is the Bargfeld, Kr. Uelzen, hoard (Fig. 4). A lot of different objects are situated with the hanging vessel (Sprockhoff, Höckmann 1979, p.386). Traditionally, there are two golden hair or finger-rings in Period III. Later, more than 12 arm-rings, two kidney-rings, and two different types of fibulae (Spindlersfeld and Lüneburg) can be found. Sixteen small ornamented discs and four tutuli are part of a horse bridle. Weaponry is represented by three lance-heads. The fibulae and the amount of arm-rings belong to the accoutrement of more than one woman. That more people are part of a ritual is shown by the hoard from Barnekow, Kr. Wismar, as well (Sprockhoff, Höckmann 1979, p.313). Two pairs of spiral arm-rings, two golden hair or finger-rings, two arm-rings and two leg-rings were found in this hoard. Part of the woman's dress is a set with three neck-rings with torsion and a hook terminal. Tools are represented by an awl with a massive handle

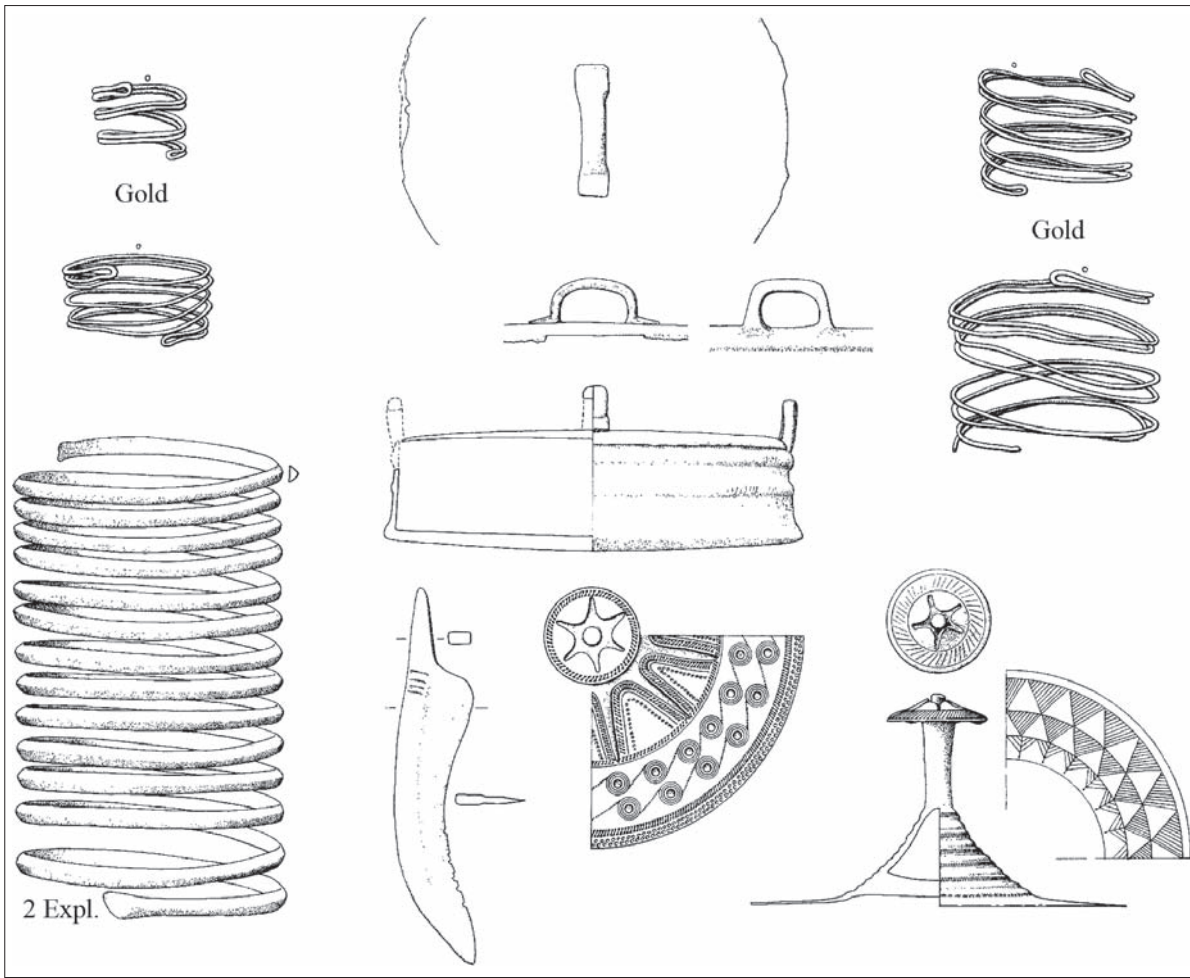

Fig. 2. The Brunsmose hoard (after Aner, Kersten 1977, Plates 67 and 1745).

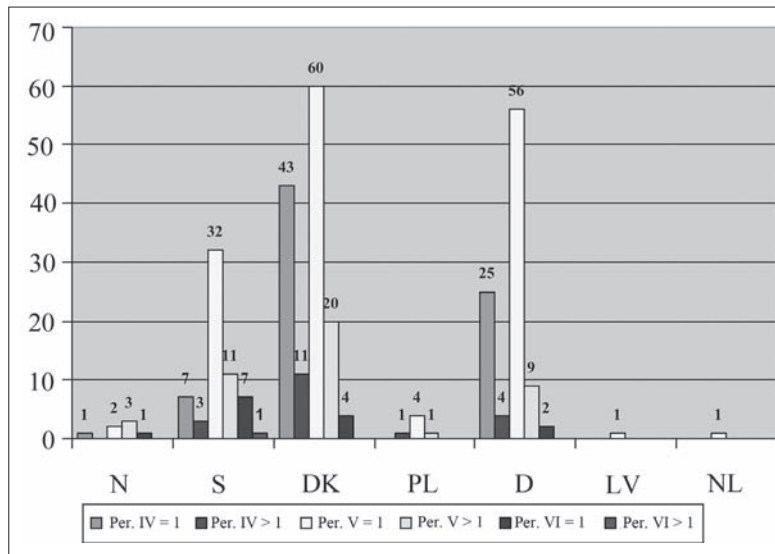

Fig. 3. Depositions with hanging vessels in Period IV and Period V.



IMMO  
 HESKE

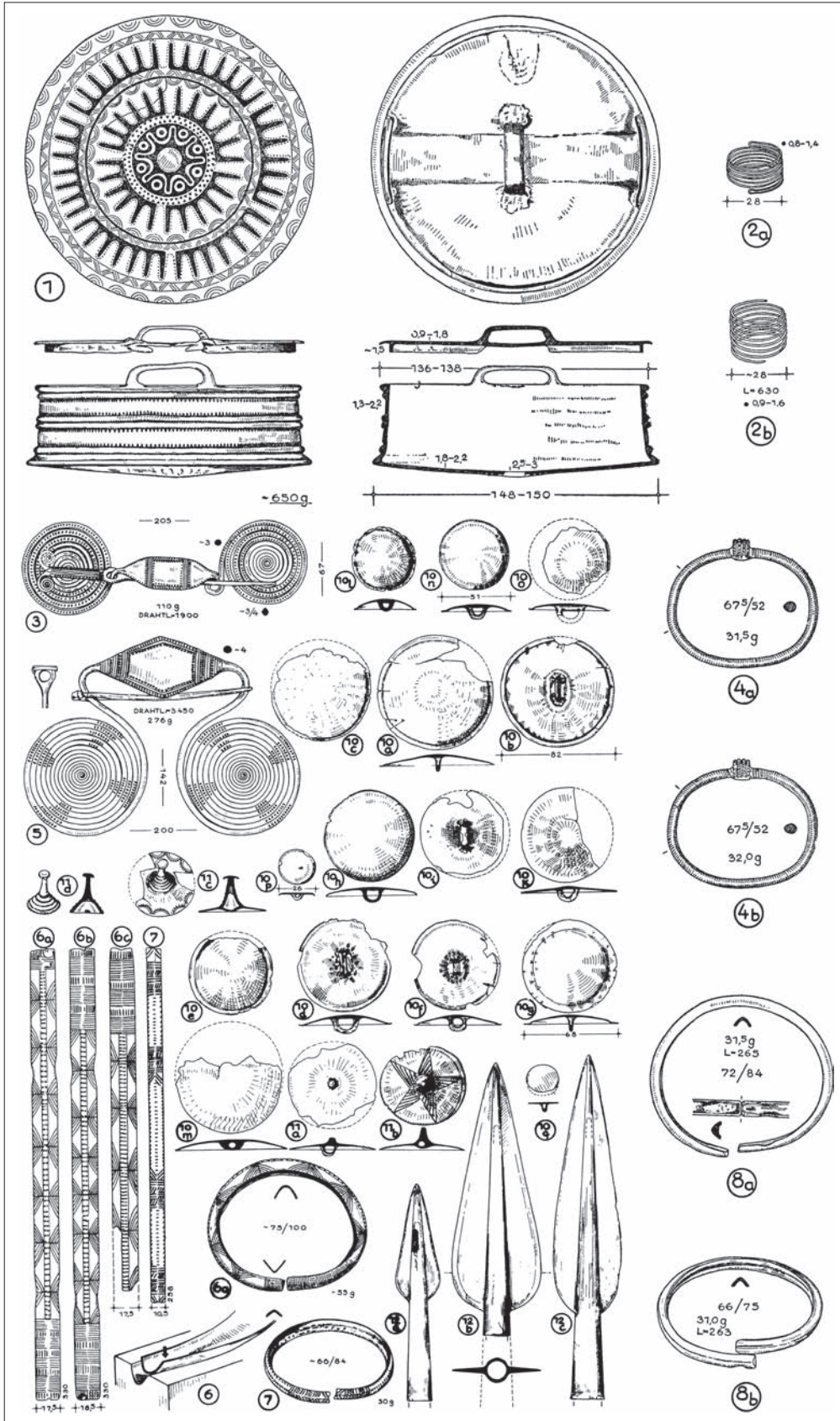

Fig. 4. The Bargfeld hoard (after Bath 1953/55, Fig. 1, Plate XXXI).

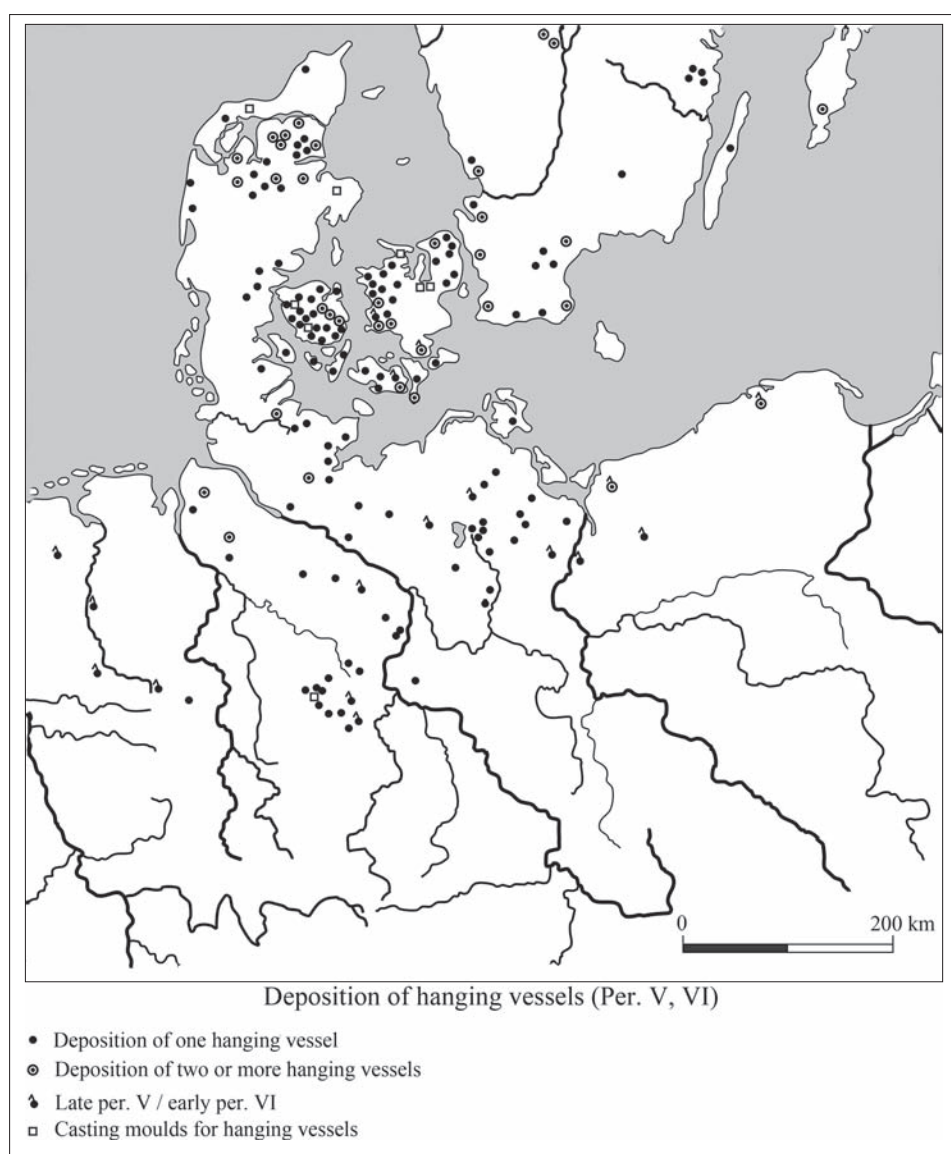

Fig. 5. The distribution of hanging vessels in Period V, in connection with the casting moulds for hanging vessels (hanging vessels after Heske 2001; casting moulds after Jantzen 2008; with the author's additions).

and two socketed axes. The latter look towards the beginning of Period V.

The depositions of Period IV clearly show a change in behaviour. During Period III, votive offerings sometimes represented more than one person, and were generally more richly equipped than the grave goods. A reevaluation of hoards can be observed for the first time in northern Mecklenburg, for example the Barnekow hoard. Now they contain more than one *pars-pro-toto* equipment for women, sets of arm-rings, and often parts of a horse bridle; sometimes these are supplemented by tools or weapons. In Period IV, the regional groups have special attributes in hoards with hanging vessels in the area south of the Baltic Sea (Heske 2009, p.173). The area close to the coastline of the Baltic Sea is the central region of this change.

Widespread change with similar behaviour nationwide indicate strong communications, shown by the right knowledge of what to do with the hanging vessels. The knowledge of the right use was part of ritual action in different settlement communities or landscapes.

#### Widespread distribution in Period V

The depositions in Period V are based on a nationwide model, and regional equipment could be laid down. In this period, hoards containing hanging vessels expanded in various directions, and reached the highest number. Sometimes two hanging vessels were deposited in pairs, or after a short time in the same site (Fig. 3). The number of hoards with hanging vessels increased, and new regions became part of the communication area

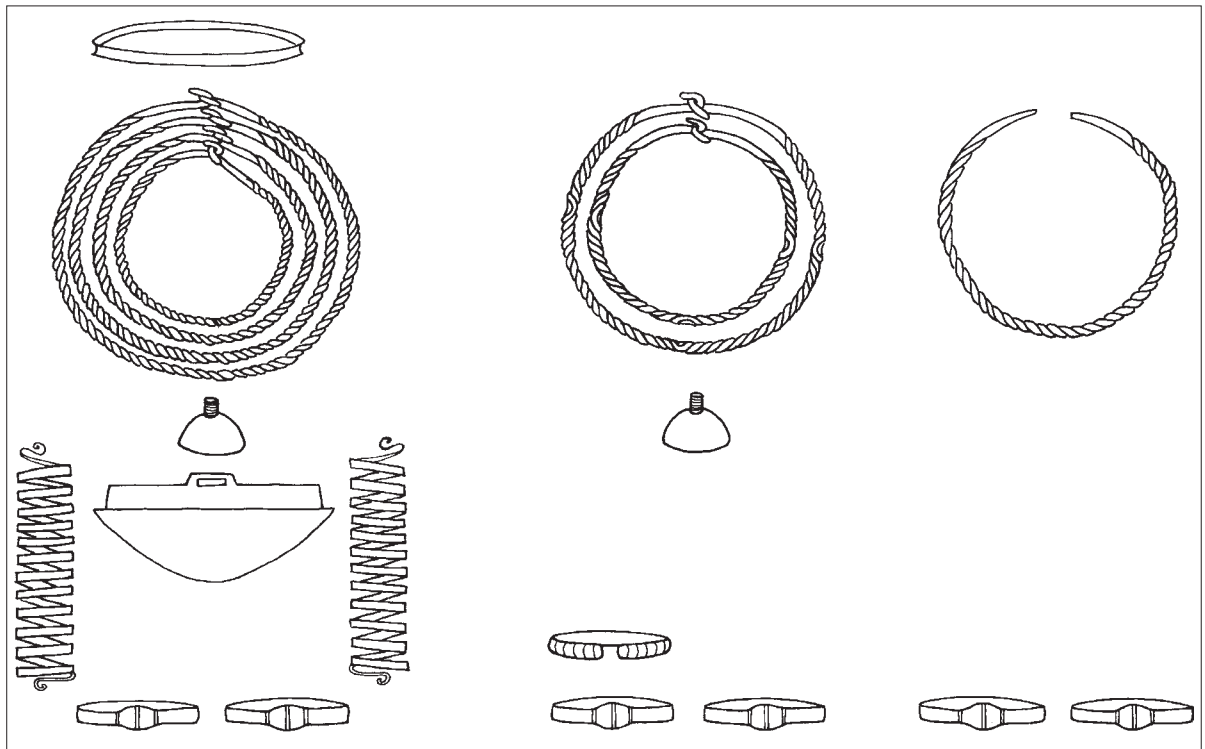

Fig. 6. The Lübbersdorf hoard in symbols (after v. Brunn 1980, Plate 41).

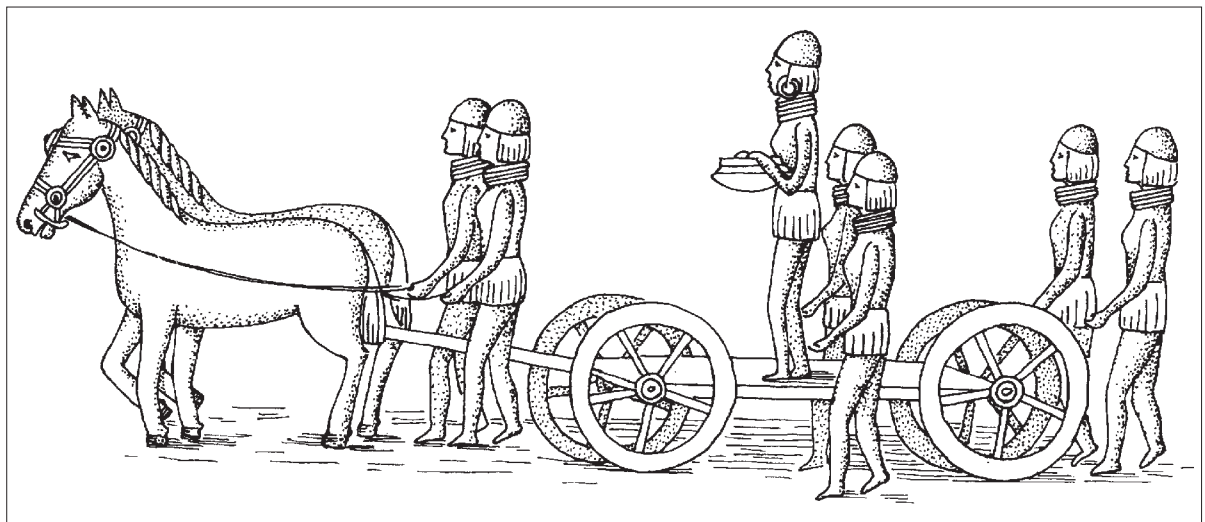

Fig. 7. A ritual procession with women and a hanging vessel (after v. Brunn 1980, Fig. 1).



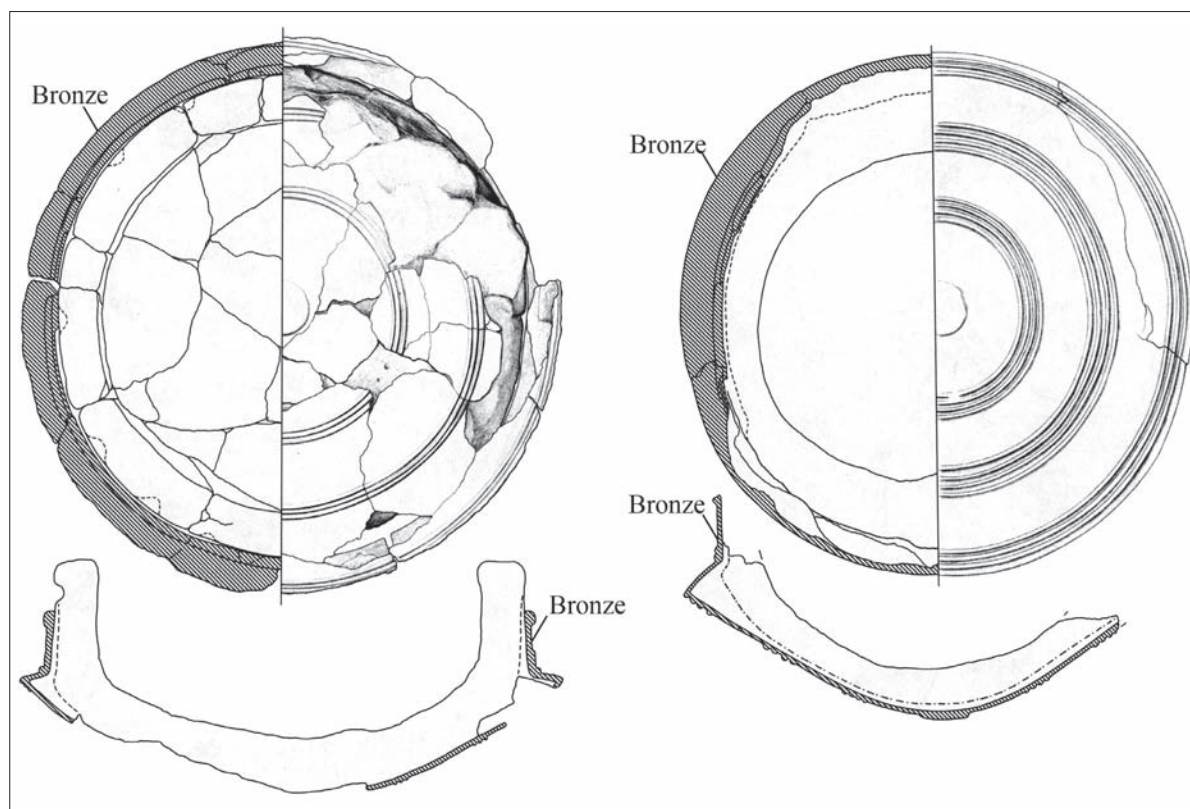

Fig. 8. Casting moulds with damaged hanging vessels from Kerte and Sandager (both DK) (after Jantzen 2008, Plates 14.53; 15.55).

(Fig. 5). Between the rivers Elbe and Weichsel, these rituals became increasingly intensive as well.

The example of Lübbersdorf, Kr. Neubrandenburg (Sprockhoff, Höckmann 1979, p.345) shows the content of a Period V hoard (Fig. 6). It can be separated into three women's sets, which contain pars-pro-toto equipment with six kidney-rings, one pair of spiral arm-rings, and two belt knobs. The equipment for three women is clearly shown by three sets of neck-rings with torsion and hook terminals.

An analysis and discussion of the combination of bronze objects in Period V hoards produce important results (v. Brunn 1980):

1. Hanging vessels and parts of women's jewellery were found together at a rate of 90%.
2. Hanging vessels, parts of women's equipment and of horse bridles were found together at a rate of 30%.
3. Women's equipment contains different neck and arm-ring sets for more than one woman.
4. Socketed axes or chisels, lance heads and working tools can be part of the hoard as well.

Often, one pair of spiral arm-rings and a *Plattenfibel* (plate fibula) are significant for one woman, while the

other women were equipped with different arm and neck-rings. The depositions were part of a ritual procession in which some (one to six) women took part (Fig. 7). They were not imported goods. It was important for the settlement community and their gods.

#### High-quality metalwork

The hanging vessels and lurs are the achievements of Nordic Bronze Age metalwork (Jantzen 2008, p.265). The very thin vessel walls with a composed profile and rich decoration with fine ornamentation are the result of high-quality and specialised metalwork. The remains for each object are ceramic casting moulds, broken into different pieces after the melting process was finished. On two sites, the casting process was done in the wrong way, and bronze remains with parts of the casting moulds were thrown away (Fig. 8). More often, these small fragments are preserved in the waste of refilled settlement pits. After the studies by Jantzen (2008, p.70), sites with remains of the casting process for hanging vessels can be located in the core region of the Nordic Bronze Age in six sites (Fig. 5).

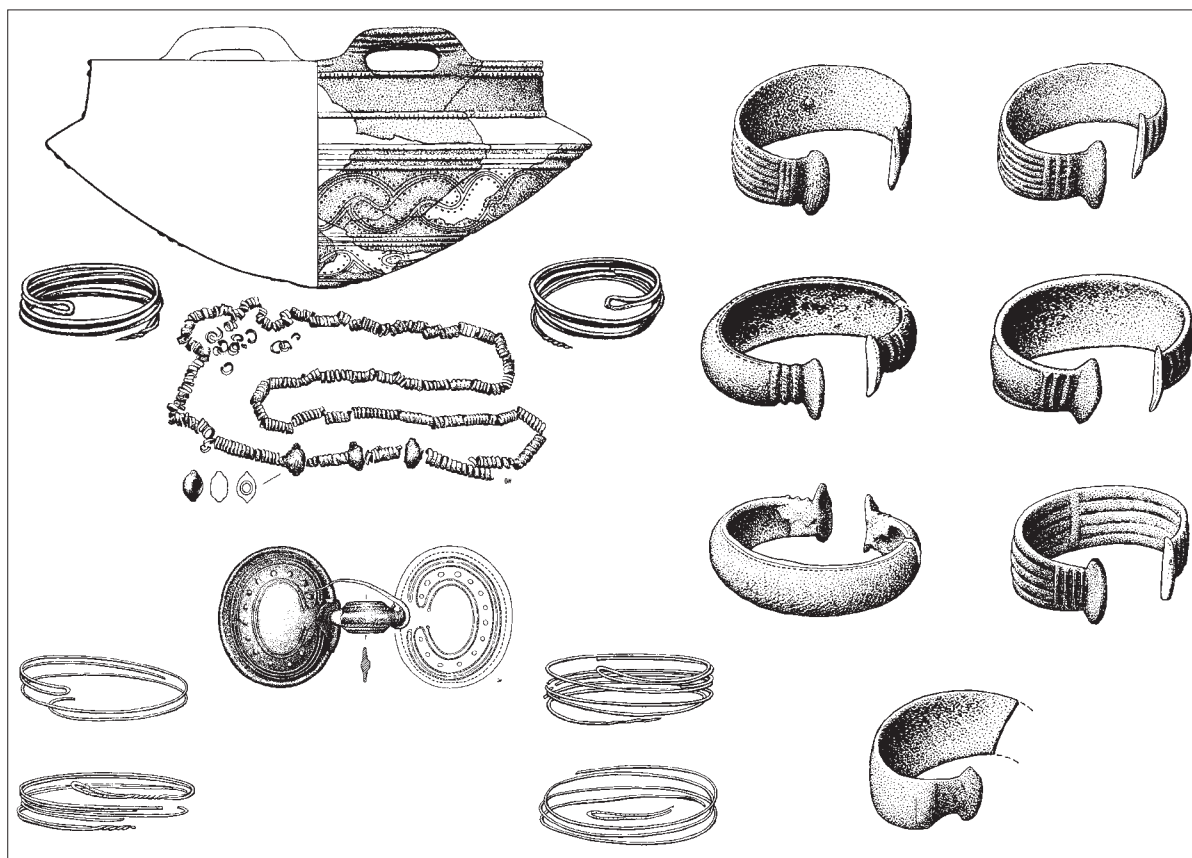

Fig. 9. The Drouwen hoard (after Butler 1986, Figs. 20-22).

### The periphery of the Nordic Bronze Age

The archaeological groups located on the periphery of the Nordic Bronze Age used different ritual behaviour and burial practices, in addition to the arrangement of the graves. In these regions, similar rare hanging vessels were found. So it is debatable whether the knowledge of utilisation was communicated from the core region, or if it was just an imported good used in a different way.

In 1939, the 'Princess of Drouwen' was found (Sprockhoff, Höckmann 1979, p.430). In a regional-style urnfield with keyhole-ditches, a hoard was found in one of them and published by Butler (1986). The Drouwen hoard, Prov. Drente (in the Netherlands), contains (Fig. 9) a hanging vessel, one plate fibula, ten (or seven) bracelets, two pairs of similar ones, and six others of local tradition (Butler 1986, p.156), two pairs of large and one pair of small spiral arm-rings, associated with one neck-ring, made of 13 different glass beads and different small spiral-tubes (Spiraldraht). Parts of a horse bridle were found as well.

The equipment is within the range of v. Brunn's combinations for hoards with hanging vessels and one plate

fibula. The neck-rings and the spiral arm-rings show us the remains of a distinguished woman, the bracelets could be shared between two to four women. For the Drouwen site, 'at the end of a Nordic rainbow' (Butler 1986, pp.133, 149), it is more than possible that some people or the whole community of the settled area had the knowledge to give the hoard to the gods in the 'right' way. Similar hoards to Drouwen were found at Broock, Kr. Parchim (Sprockhoff, Höckmann 1979, p.319ff), in Mecklenburg-Vorpommern and Karolinenhof, (formerly Kr. Greifenberg in Pommern; today Cieszyce, Gryfice, Poland) (Sprockhoff, Höckmann 1979, p.304).

In the Drouwen urnfield there is a second indicator for the understanding or misunderstanding of local rituals. In the field of keyhole-ditches there is one stone cist, which is very unlikely to relate to regional burial practices. The grave goods with two pots, a razor and a pair of tweezers are outstanding (Butler 1986, p.154). The best parallels can be found in the area between the North Sea and the Baltic Sea. This grave gave us a glimpse at the presence of a group of people from another region.



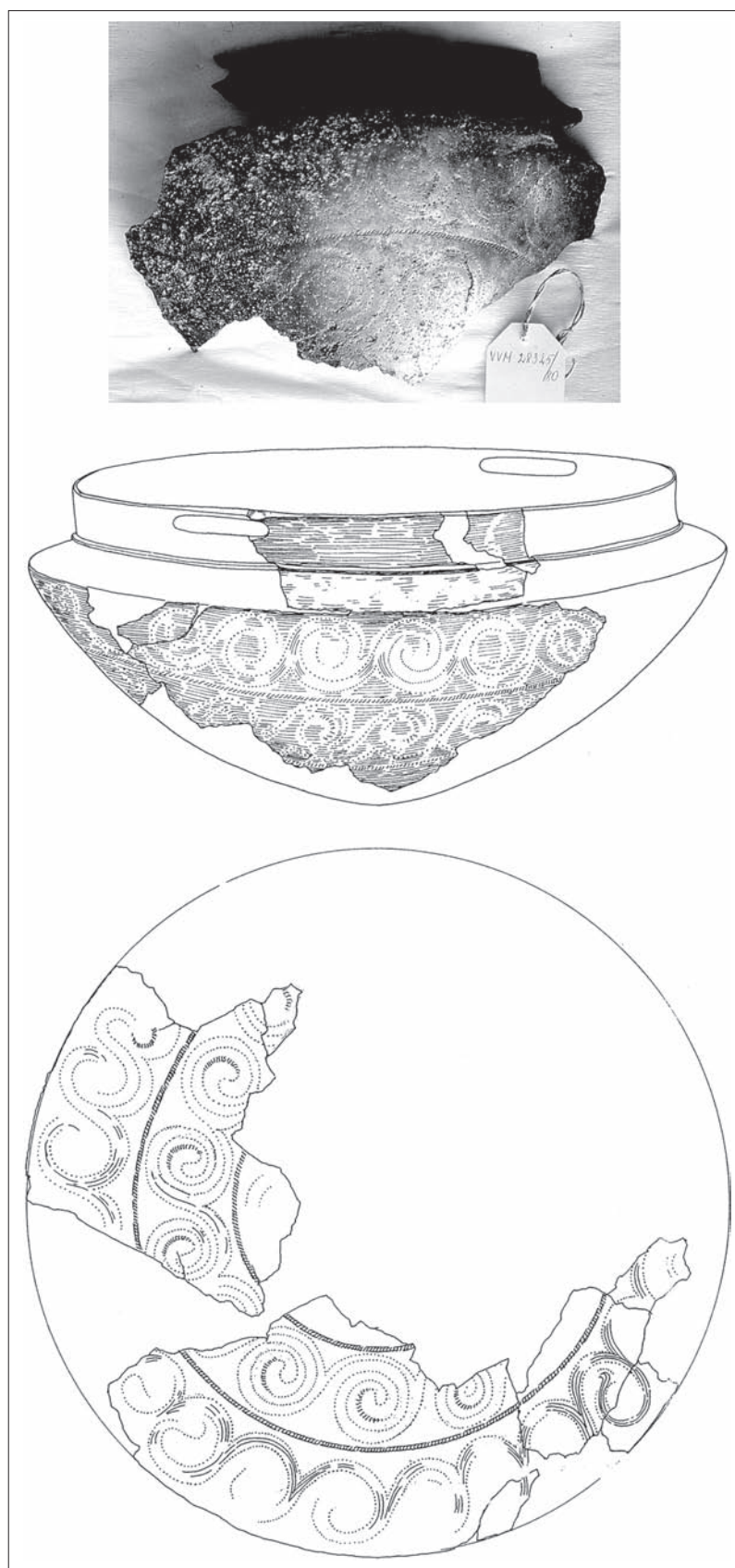

Fig. 10. The Staldzene hoard, a partly damaged hanging vessel (after Vasks, Vijups 2004, Fig. XX; photograph by I. Heske).

I  
 EARLY METAL  
 AGE SOCIETIES:  
 FROM A  
 THEORETICAL  
 ASSESSMENT  
 TO THEIR  
 ECONOMY,  
 INTERREGIONAL  
 CONTACTS  
 AND RITUALS

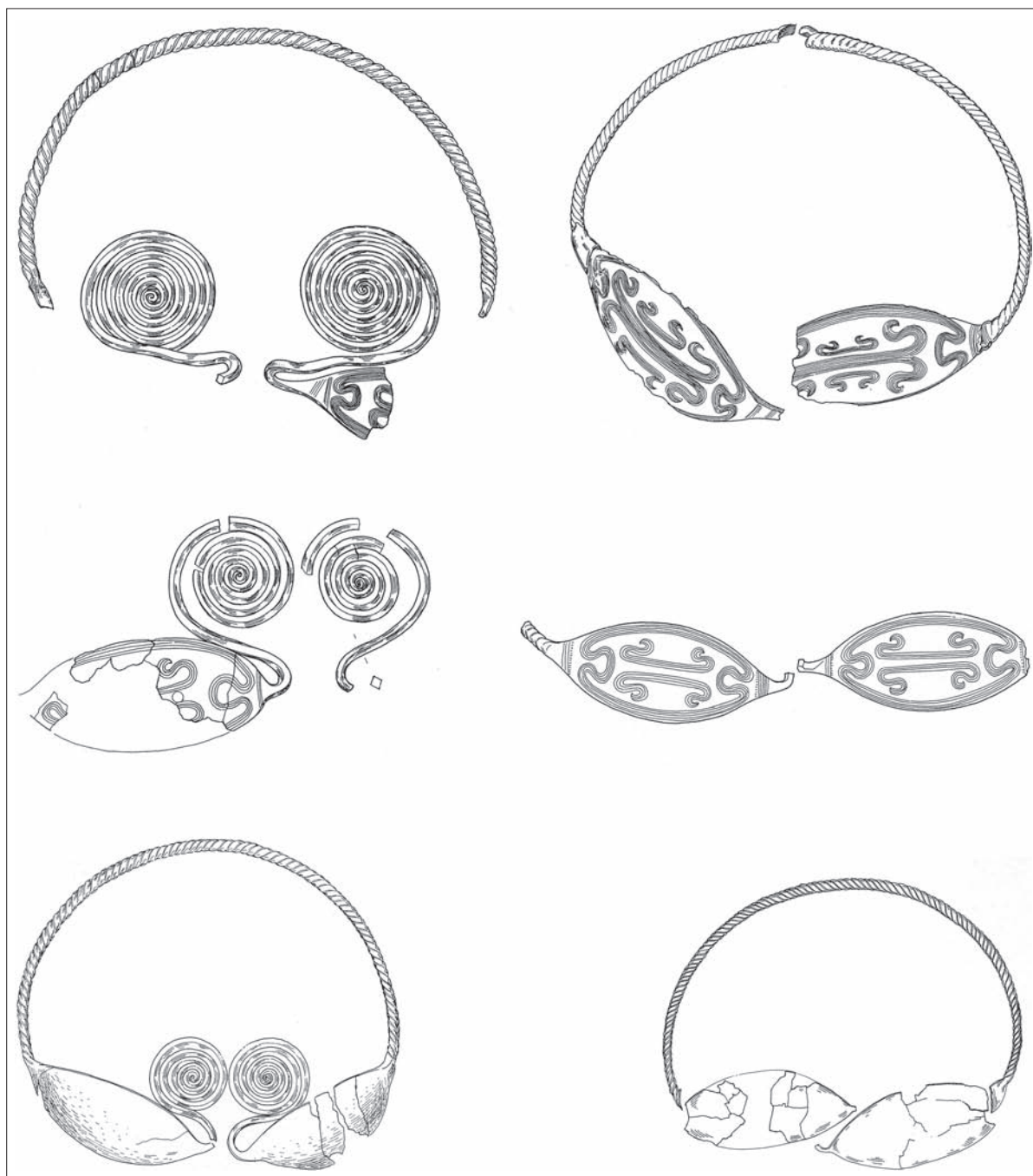

Fig. 11. The Staldzene hoard, three pairs of neck-rings with different decorations (after Vasks, Vijups 2004, Figs. IX.1-2; VII.1; IX.3; VII.2; VIII.1-2).

### Looking over the border of the Nordic rainbow to the east

In 2001, near the mouth of the River Venta, a short distance from Staldzene, very close to Ventspils in Latvia, a hoard of 88 bronze artefacts weighing over five kilogrammes was found after a stormy day which caused some coastal erosion (Vijups, Vasks 2004). Altogether, a total of four needles, about 34 arm-rings, 12 spiral-rings, six neck-rings with torsion and leaf-

shaped terminals, one pair of spiral arm-rings, and one plate fibula were collected from the sandy soil.

Included in this deposition was one hanging vessel, decorated with ornaments from the Nordic Bronze Age (Fig. 10). It is very important to take a closer look at the neck-rings with torsion and decorated oval plates (Vijups, Vasks 2004, Plates VII-IX). The six items can be divided into three pairs. One ring with hook terminals and one with flat spiral endings were made using the same technique. Each pair with different endings is decorated in the same way:

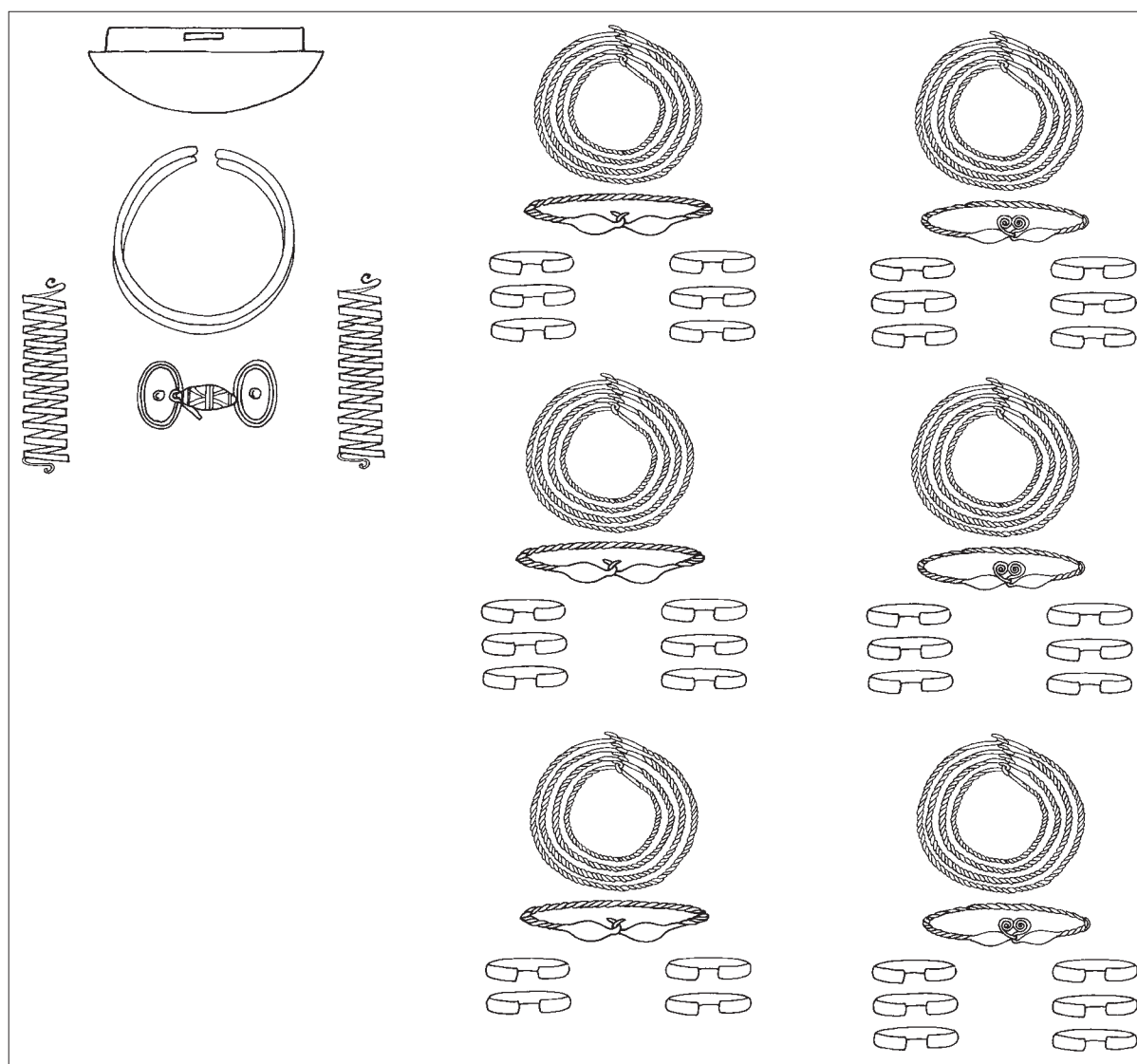

Fig. 12. The Staldzene hoard in symbols.

The first pair has no decoration on the leaf-shaped terminals.

The second one shows a double-ship symbol, made of four scratched lines.

The third one is engraved with two double-ship symbols, made of seven scratched lines (Fig. 11).

The Staldzene deposition is one of the most intact hoards for female participants. The outstanding woman is represented by the plate fibula, two neck-rings and a pair of spiral arm-rings. The other six women wear a neck-ring with decorated plates and four neck-rings with torsion; on each arm they wear three bracelets (Fig. 12).

Another example of a combination of neck-rings with decorated plates and different endings comes from the hoard from Deinstedt, Kr. Rotenburg/Wümme in Lower Saxony (Sprockhoff, Höckmann 1979, p.388ff)

and Iloher Heide, Kr. Rendsburg-Eckernförde (Sprockhoff, Höckmann 1979, p.402), Schleswig-Holstein.

Furthermore, the Staldzene hoard contains fragments of a horse bridle represented by horse harness decoration. Very similar to these items are the harness decorations from Stolzenburg, Kr. Uecker-Randow, Ückeritz on the island of Usedom, Kr. Ostvorpommern (Lampe 1982, p.25, Taf. 44) and Hellwitt, Ksp. Nottmark, on the island of Alsen (Sprockhoff 1956, p.262, Taf. 58).

The combination of the neck-rings, the equipment of the distinguished woman and the fragments of the horse harness is very similar to many depositions in the Baltic Sea area. But the Staldzene hoard is one of the best examples of a well-structured combination of objects. The deposition is not the result of a forgotten merchant's deposition or a lost metal collection. It is one of the best examples of the knowledge of rituals, practised in a core region of the Nordic Bronze Age.





Fig. 13. Details of the decoration of the hanging vessels from Watenstedt II and Deersheim I (Heske 2008, Fig. 4-5).

The decorated pins and the equipment of the hoard do not point in the direction of the southern shore of the Baltic Sea. The best parallels can be found in the hoard from Fårhult in southeast Sweden (Sprockhoff, Höckmann 1979, p.23). The geographical distance between Ventspils/Staldzene and Fårhult can be crossed with small ships. In this context, we have to remember the characteristically Scandinavian ship-graves of northern Kurzeme (Courland) (Capelle 1986, p.55, Fig. 2).

#### And in the south: Nordic or Lusatian knowledge?

In the southern part of the distribution area for hanging vessels, the situation is different. A concentration of finds on the border of the map can be found at a distance of around 200 kilometres from the centre of distribution near the Baltic Sea. Thirteen hanging vessels seem to be in the core region of the Nordic Bronze Age, but they were found near the Harz Mountains in Lower Saxony and Saxony-Anhalt. In the 1960s, Sprockhoff (1966, p.110) published some thoughts about a production centre in this area. Further studies in recent years, and work with the original material, provide new arguments for Sprockhoff's and later Höckmann's ideas locating one *Werkstatt* in the north Harz region (Heske 2008).

For the first time, the ornamentation of hanging vessels from Watenstedt II and Deersheim I is very similar (Heske 2008, p.30). Secondly, similar careless mistakes in the ornamentation can be detected (Fig. 13). The distance between the two sites is about 18 kilometres.

Other hanging vessels show different stages of a technical and ornamental relationship. For some sites, like Deersheim and Watenstedt, the rituals and votive offerings were performed more than once. Like the examples from Drouwen and Staldzene, the hoards contained the same well-known equipment. One plate fibula and a pair of spiral arm-rings are preserved from the Watenstedt I site (Fig. 14). In addition, needles, bracelets and small spiral arm-rings were found. Four sickles represent the tools (Voges 1901). The Watenstedt II hoard, discovered between 1903 and 1907 (Fig. 15), contains one plate fibula and two pairs of spiral arm-rings. Jewellery is represented by needles, and parts of a horse bridle are preserved (Voges 1913; Heske 2001).

For the region north of the Harz Mountains, the situation differs from the features found in Drouwen and Staldzene. The knowledge of the correct use of hanging vessels is spread over a wide area. The ritual was performed at least 13 times in the right context, and far from the traditional core region of the Nordic Bronze Age.

In this region, the settlement system is completely different to the area in the western Baltic. The ceramics are made in the local style, called *Saalemündungsgruppe* and *House-Urn-culture* (Heske 2006, p.57). Hill-forts are centres in the cultural region.

In the last few years, a project by the Deutsche Forschungsgemeinschaft was initiated by the University of Göttingen, to get a new and closer insight into one hill-fort in this area. Geophysical prospecting was carried out over 28 hectares. Different features were detected that justified further excavations of the outer settlement (Heske, Posselt 2009; Heske *et al.* 2010). In

I  
 EARLY METAL  
 AGE SOCIETIES:  
 FROM A  
 THEORETICAL  
 ASSESSMENT  
 TO THEIR  
 ECONOMY,  
 INTERREGIONAL  
 CONTACTS  
 AND RITUALS

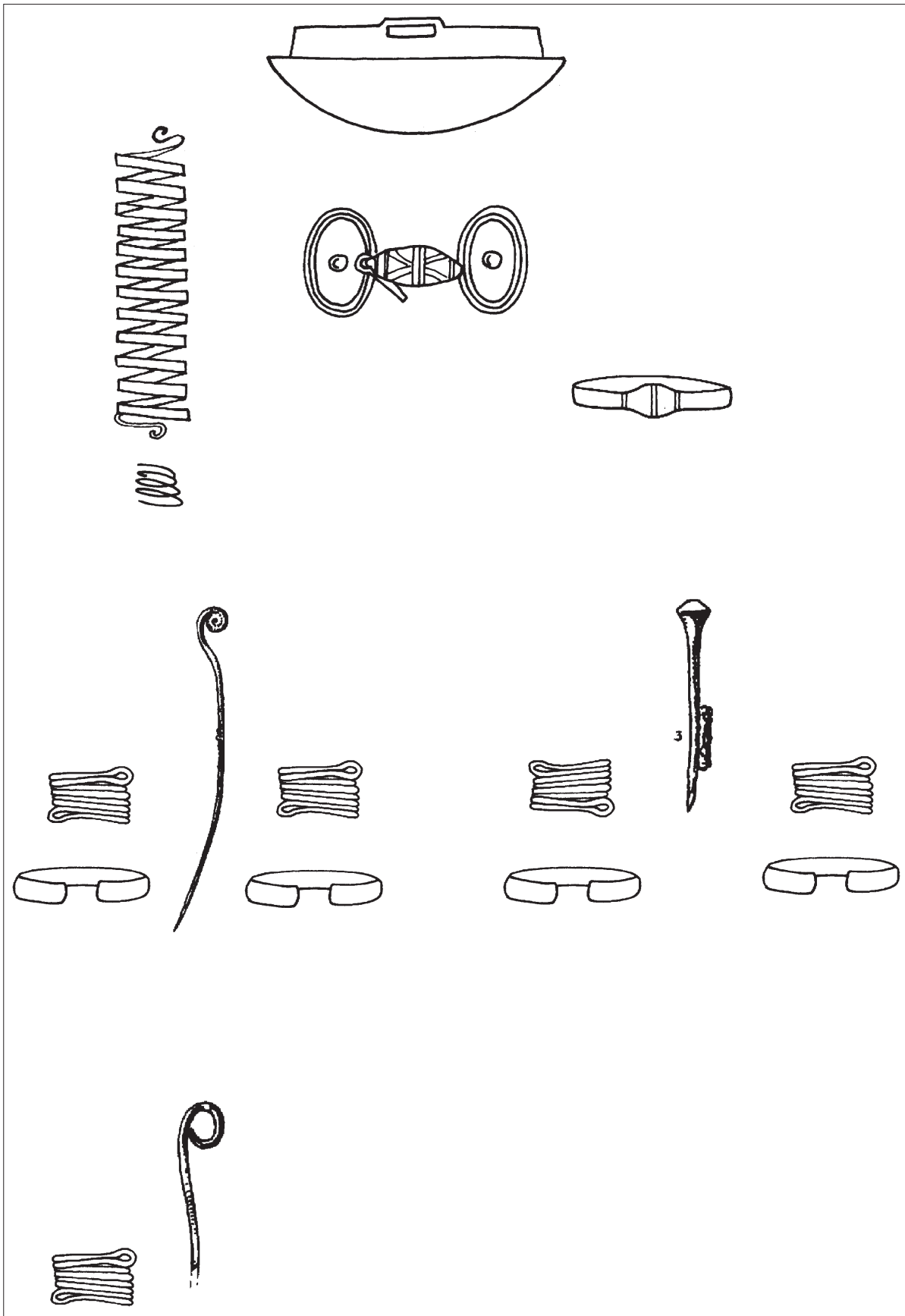

Fig. 14. The Watenstedt I hoard in symbols.

IMMO  
 HESKE

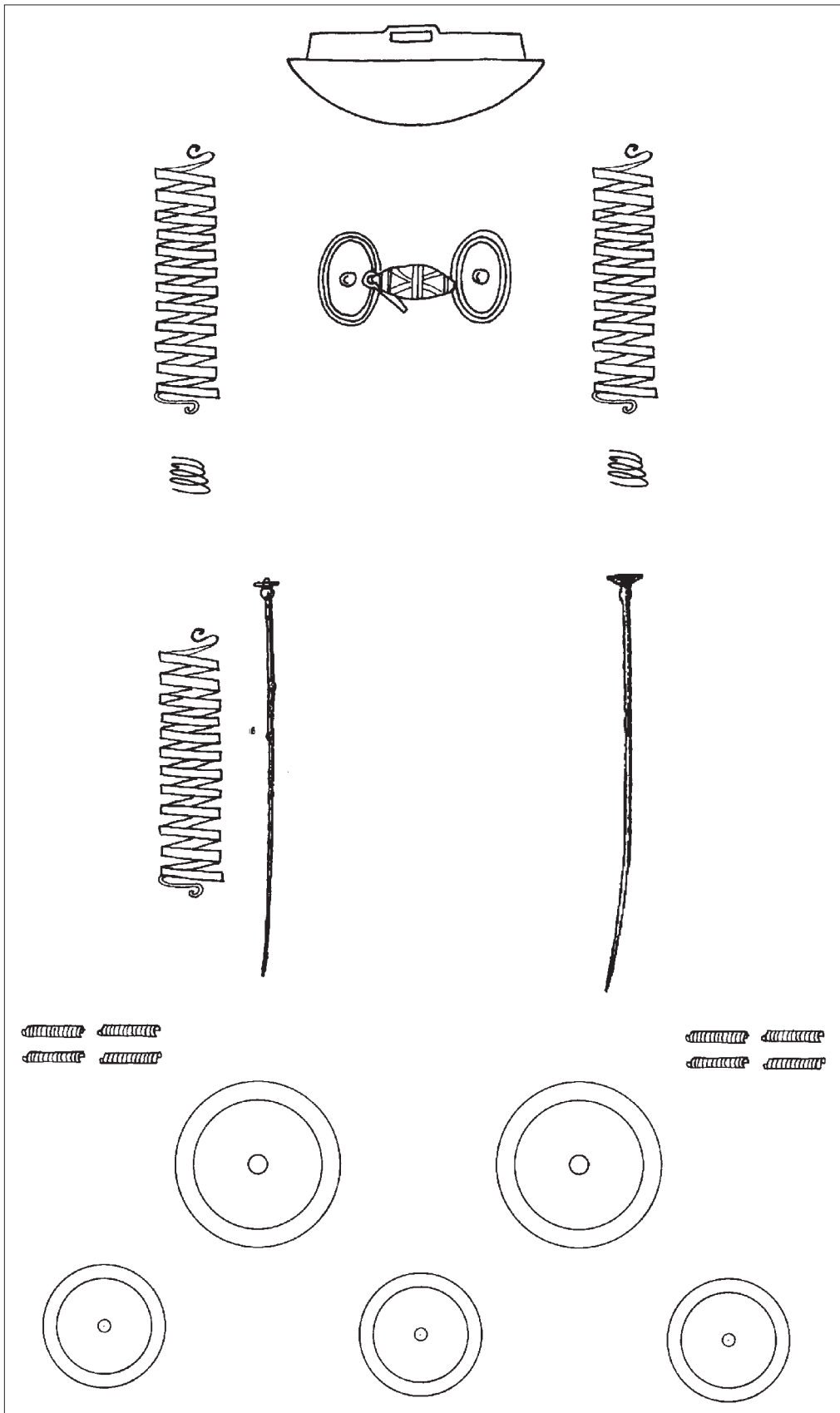

Fig. 15. The Watenstedt II hoard in symbols.



the outer settlement, excavations were conducted over the last six years.

After mapping the geophysical prospecting, old creeks could be visualised, and correspond with old maps from the middle of the 18th century, showing a wet area north of today's Soltau Creek (Plate I.1). This place was the site where two hoards with hanging vessels were found in the early 20th century.

So, we come to the end, and finally look at the production. Not only were hanging vessels found near Watenstedt, but also the remains of the casting process for sickles, neck-rings, spearheads, horse bridles and swords could be found during excavations in the outer settlement. While working with the finds after the catalogue was written, a negative model for hanging vessels was identified, which could be connected with the hanging vessel found in 1901 (Plate I.2). A small fragment of the inner part of a casting mould for a second hanging vessel was identified as well. We have to consider that the Watenstedt site was a production centre on the periphery. Sprockhoff's idea was right. Mapping the hanging vessels in the north and the northern part of Central Europe, and taking into consideration the equipment behind the depositions, it becomes obvious that there is a common idea of 'doing the right thing' with bronze. It gives us an insight into the close contacts in this area, and the ritual knowledge that is well known by settlement groups.

The people on the periphery of the Nordic Bronze Age, like Drouwen and Staldzene, are part of the same knowledge community. In combination with the casting moulds of the hanging vessels and the depositions at the same place, the migration of different groups (Heske *et al.*, forthcoming, 2013) over a long distance from north to south in the Late Bronze Age could have been part of the living world.

## Summary

In Period III, the first hanging vessels were produced in the west Baltic Sea region. First found mainly in graves, their importance as parts of depositions increased during Period III. They were deposited in different regions on the Danish isles, but they had a restricted content. In the later phase of the Bronze Age, a wide distribution can be assumed, touching the end of the 'Nordic rainbow'. The depositions on the periphery, the Netherlands in the west and Latvia in the east, show a similar knowledge of use and deposition as in the core region of the Nordic Bronze Age. In the southern periphery north of the Harz Mountains, the distribution map shows a huge concentration of hanging vessels. More than the knowledge is preserved.

Casting moulds and the same decorations on the found objects can be interpreted as a production centre. Arguments for the mobility of a group from north to south become evident.

## References

- ANER, E., KERSTEN, K., 1977. *Bornholms, Maribo, Odense und Svendborg Amter*. Die Funde der älteren Bronzezeit des nordischen Kreises in Dänemark, Schleswig-Holstein und Niedersachsen, III. Neumünster, København: Wachholtz, Nationalmuseum.
- BATH, F.C., 1953/55. Der bronzezeitliche Hortfund von Bargfeld, Kr. Uelzen. *Hammaburg N.F.*, 4, 79-82.
- v. BRUNN, W.A., 1980. Eine Deutung spätbronzezeitlicher Hortfunde zwischen Elbe und Weichsel. *Bericht der Römisch-Germanischen Kommission*, 61, 91-150.
- BUTLER, J.J., 1986. Drouwen: end of the "Nordic" rainbow? *Palaeohistoria*, 28, 133-168.
- CAPELLE, T., 1986. Schiffssetzungen. *Prähistorische Zeitschrift*, 61, 1-63.
- HESKE, I., 2001. Neue Bruchstücke eines Bronzebeckens aus dem Hortfund von Watenstedt, Kr. Helmstedt. *Kunde N.F.*, 52, 79-88.
- HESKE, I., 2006. *Die Hünenburg bei Watenstedt, Kr. Helmstedt – Eine ur- und frühgeschichtliche Befestigung und ihr Umfeld*. Göttinger Schriften zur Vor- und Frühgeschichte, 29. Neumünster: Wachholtz.
- HESKE, I., 2008. Identifizierung und Datierung von Bronzefragmenten aus Börßum, Kr. Wolfenbüttel. Zur Fundkonzentration der gegossenen Bronzebecken am Nordharz. *Neue Ausgrabungen und Funde in Niedersachsen*, 27, 25-38.
- HESKE, I., 2009. Kultpersonal in einer fremden Welt. – Deponierungen mit gegossenen Bronzebecken an der Peripherie der Nordischen Bronzezeit. In: A. KRENNLEEB, H.-J. BEIER, E. CLASSEN, F. FALKENSTEIN, S. SCHWENZER, eds. *Varia neolithica V. Mobilität, Migration und Kommunikation in Europa während des Neolithikums und der Bronzezeit*. Tagung AG Neolithikum/ Bronzezeit Xanten, Juni 2006. Beiträge zur Ur- und Frühgeschichte Mitteleuropas 53. Langenweissbach, 171-179.
- HESKE, I., POSSELT, M., 2009. Archaeology and Landscape Features in Magnetometer Data. In: Colloque organisé par Christophe Benech, Denis Fabre, Armin Schmitt, Alain Tabbagh. *Mémoire du sol, espace des hommes*. 8-12 Septembre 2009, Conservatoire National des Arts et Métiers (CNAM) - Paris. *Archeosciences, Rev. d'Archéométrie* 2009, Supplément au n° 33. Rennes, 137-139.
- HESKE, I., GREFFEN-PETERS, S., POSSELT, M., WIETHOLD, J., 2010. Die jungbronzezeitliche Außensiedlung der „Hünenburg“ bei Watenstedt, Lkr. Helmstedt. Vorbericht über die Ausgrabungen 2005–2007. *Prähistorische Zeitschrift*, 85 (2), 159-190.
- HESKE, I., LÜTH, P., POSSELT, M., forthcoming, 2013. Niederlegungs- und Gargrubenfeld. Zur Infrastruktur der Hünenburg-Außensiedlung bei Watenstedt, Kr. Helmstedt. Vorbericht über die Grabung 2011.
- HÖCKMANN, O., 1974. Zu den Resten nordischer Bronzebecken aus dem Fund von Petit-Villatte. In: A. ALFÖLDI, K. TACKENBERG, eds. *Festgabe K. Tackenberg zum 75 Geburtstag, Antiquitas, Reihe, 2*. Bonn, 85-109.

- HÖCKMANN, O., 1981. Ein verschollenes Bronzebecken aus „Braunschweig“. *Jahrbuch des Römisch-Germanischen Zentralmuseums*, 28, 82-132.
- HUNDT, H.-J., 1944-50. Die Bronzedosen der älteren Bronzezeit Mecklenburgs. *Germania*, 28, 197-209.
- JANTZEN, D., 2008. Quellen zur Metallverarbeitung im Nordischen Kreis der Bronzezeit. *Prähistorische Bronzefunde* XIX, 2. Stuttgart: F. Steiner Verlag.
- LAMPE, W., 1982. *Ückeritz. Ein jungbronzezeitlicher Hortfund von der Insel Usedom*. In: Beiträge zur Ur- und Frühgeschichte der Bezirke Rostock, Schwerin und Neubrandenburg. Berlin: VEB Deutscher Verlag der Wissenschaften.
- MÜLLER, S., 1878. *Die nordische Bronzezeit und deren Periodentheilung*. Jena: H. Costenoble.
- SPROCKHOFF, E., 1956. *Jungbronzezeitliche Hortfunde der Südzone des nordischen Kreises (Periode V)*. Kataloge des Römisch-Germanischen Zentralmuseums, 16. Mainz: Verlag des Römisch-Germanischen Zentralmuseums.
- SPROCKHOFF, E., 1966. Ein Geschenk aus dem Norden. In: R. DEGEN, W. DRACK, R. WYSS, eds. *Helvetia Antiqua. Festschrift Emil Vogt*. Zürich, 101-110.
- SPROCKHOFF, E., HÖCKMANN, O., 1979: *Die gegossenen Bronzebecken der jüngeren nordischen Bronzezeit*. Römisch-Germanisches Zentralmuseum. Kataloge vor- und frühgeschichtlicher Altertümer, 19. Mainz: Verlag des Römisch-Germanischen Zentralmuseums in Kommission bei R. Habelt.
- WILLROTH, K.-H., 1985. Aspekte älterbronzezeitlicher Deponierungen im südlichen Skandinavien. *Germania* 63, 362-400.
- VASKS, A., VIJUPS, A., 2004. *Staldzenes bronzas laikmeta depozīts (Staldzene bronze age hoard)*. Riga: Fobo Prints.
- VOGES, T., 1901. Der Depotfund von Watenstedt. *Nachrichten über Deutsche Altertumsfunde*, 12, 81-90.
- VOGES, T., 1913. Fundbericht über den Depotfund von Watenstedt am Hees. *Braunschweigisches Magazin* 19, 30-32.

Received: 4 May 2012; Revised: 10 September 2012;  
Accepted: 17 October 2012.

Immo Heske  
Institute of Prehistory  
University of Göttingen  
Nikolausberger Weg 15  
D-37073 Göttingen  
E-mail: iheske@gwdg.de

## ŽINIOS APIE RITUALUS: VĒLYVOJO BRONZOS AMŽIAUS KABINAMŪJŲ INDŪ GAMYBA, PAPLITIMAS IR RADAVIETĒS

IMMO HESKE

### Santrauka

Bronzos amžiaus III periode pirmieji kabinamieji indai buvo pagaminti vakariniame Baltijos jūros regione. Pirmiausia jų daug buvo rasta kapuose, bet jų lobių svarba išaugo III periodu (1–15 pav.; I iliustr.). Šių indų tam tikri rinkiniai buvo užkasami į žemę įvairiuose Danijos salų regionuose. Vėlyvojoje bronzos amžiaus fazėje galima numanyti juos paplitus plačiau ir pasiekus „Šiaurės vaivorykštės“ galą. Radaviečių arealo periferijoje – Nyderlandų vakaruose ir Latvijos rytuose – rasti dirbiniai liudija panašų jų naudojimo ir aukojimo paprotį kaip ir pagrindiniame jų paplitimo regione bronzos amžiuje. Pietinėje periferijoje, į šiaurę nuo Harco kalnų, kabinamųjų indų paplitimo žemėlapis rodo didžiulę jų koncentraciją. Čia buvo išsaugotos ne tik žinios apie ritualus. Liejimo formos ir panašus rastų daiktų dekoras gali būti vertinami kaip gamybos centro produktai. Šių dirbinių grupės judėjimo įrodymai šiaurės–pietų kryptimi tampa akivaizdūs.

Vertė Rasa Banytė-Rowell